

Julia Sanders

## **Dream Bedroom - 1-Point Perspective**

5th Grade

Pencil, Colored Pencil

6 - 45 minute classes

**Big Idea:** Throughout time and across cultures, people design places that have meaning and fill them with objects that reflect their identity.

**Lesson Summary:** Students will learn how to draw in 1-point perspective to give a flat 2-D drawing an appearance of depth and dimension. In designing a dream bedroom students will create a space that is personal to them and will fill it with objects that reflect parts of their identity.

**Rationale:** By learning 1-point perspective, students can show the illusion of depth and dimension on a 2-D surface. This skill will provide the building blocks to 2-point and 3-point perspective drawing. Students will learn to use art elements and principles of design to reflect places of personal significance.

**Artists:** Vincent Van Gogh, "The Bedroom", 1889

### **Key Concepts:**

- Identification of a horizontal line, vertical line, vanishing point, and orthogonal lines.
- Objects can be drawn to scale.
- A bedroom is a personal place of expression.

### **Essential Questions:**

- What is a horizontal line, vertical line, vanishing point and orthogonal line?
- How do I create the illusion of depth on a 2-D surface?
- How can I design and decorate my dream bedroom to be a reflection of my identity and interests?

### **National Standards:**

**VA:Cr2.3.5a** Identify, describe, and visually document places and/or objects of personal significance.

**VA: Cn10.1.5a** Apply formal and conceptual vocabularies of art and design to view surroundings in new ways through art-making.

**Interdisciplinary connections:** Geometric projection in mathematics.

### **Pennsylvania Standards:**

**9.1.5.A** Know and use the elements and principles of each art form to create works in the arts and humanities - color, line, shape, space and emphasis, movement, proportion/scale.

**9.1.5.B** Recognize, know, use and demonstrate a variety of appropriate arts elements and principles to produce, review and revise original works in the arts. Draw proportion/scale.

**9.1.5.E** Know and demonstrate how arts can communicate experiences, stories or emotions through the production of works in the arts.

### **Objectives: Students will...**

**Knowledge:** Demonstrate an understanding of the concepts of 1-point perspective by identifying the horizon line, orthogonal lines and the vanishing point.

**Skills:** Design and draw a bedroom in 1-point perspective to show the illusion of depth.

**Disposition:** Illustrate that as artists they can design an imaginary place to be a reflection of themselves that tells a story of their identity.

### **Assessments:**

**Pre-Assessment:** Day one is a practice day to determine student's abilities to see the orthogonal lines and identify the vanishing point in their school hallway pictures.

**Formative Assessment:** TW walk around to be sure that each step is being followed before moving on to demonstrate the next step. Real-time feedback will be given between demo steps.

**Summative Assessment:** Students will be graded on a checklist connected to a 4-pt. rubric. Drawing will be graded on craftsmanship, demonstration of 1-pt. perspective and visual documentation of personal identity in three objects.

## 6 classes 45 minutes each

### **Assessment:**

Support students one-on-one by providing answers to questions and feedback during work time. Check for correct procedures of drawing perspective and filling out planning mood board worksheet.

### **Teacher Research & Preparation:**

- Make Canva presentation
- Create exemplar
- Cut paper
- Sharpen pencils, gather rulers
- Research 1-pt perspective
- Create hallway worksheet
- Create mood board worksheet
- Create checklist and rubric
- Create examples packet

Day 1:

### **Motivation/Engagement/The Hook:**

TW announce an (imaginary) interior designer has been hired to design the student's dream bedroom with their design plans.

**Development:** TW explain 1-pt. perspective, show exemplars and VanGogh bedroom. TW demo perspective on the board with hallways. SW practice on hallway worksheets and start mood board planning sheet.

**Culmination/Close:** TW ask students to think about what they would like to put in their dream bedrooms.

Day 2:

### **Motivation/Engagement/The Hook:**

TW announce that SW start to draw their dream bedroom on drawing paper.

**Development:** TW demo how to draw walls, floor, windows, rug, and artwork on white board. SW draw step by step along with teacher on paper with pencils and rulers.

**Culmination/Close:** TW explain that SW draw the bed, furniture and objects the next class.

Day 3:

### **Motivation/Engagement/The Hook:**

TW announce that SW learn to draw a bed, furniture and objects.

**Development:** TW demo how to draw a bed, furniture and objects. SW draw their bed and complete mood board planning sheet. If students finish planning they can draw furniture and objects.

**Culmination/Close:** TW explain to students that they will continue adding details to their drawings the next class.

Day 4:

### **Motivation/Engagement/The Hook:**

TW announce that SW continue filling their bedroom with furniture, accessories and personal objects.

**Development:** SW draw their bedroom furniture, accessories and objects. The teacher will assist one on one with drawing in perspective.

**Culmination/Close:** TW explain to students that they will add color to their bedroom the next class.

Day 5:

### **Motivation/Engagement/The Hook:**

TW announce that SW add color to their bedroom drawings and finalize details.

**Development:** SW start coloring their bedroom drawings with colored pencils.

**Culmination/Close:** TW tell students that they will continue adding color to their drawings the next class.

## 6 classes 45 minutes each

Day 6:

**Studio Day:** SW continue adding details and finish the coloring of their dream bedroom drawings.

### **Student Supplies:**

- White drawing paper 8x10"
- #2 pencil, rulers, eraser
- Colored pencils in many colors
- Hallway practice worksheets
- Planning mood board
- Example packets & pictures

### **Instructional Resources:**

- Cooperating teacher - Rose Cushwa's "Draw a Bedroom in one point perspective" resource packet and previous student work as examples.
- <https://www.teacherspayteachers.com/Product/One-Point-Perspective-Bedroom-Drawing-Art-Project-Step-by-Step-Slideshow-1-pt-8319014> USED as research and for student examples.
- <https://www.artic.edu/artworks/28560/the-bedroom>. Van Gogh story.
- <https://drawpaintacademy.com/the-ultimate-guide-to-one-point-perspective/>

### **Vocabulary:**

- 1-pt. perspective
- Horizon line
- Vanishing point
- Orthogonal line
- Horizontal line
- Vertical line

### **Modifications:**

**Adapted** - SW cut out provided pictures of bedroom elements and glue onto paper. SW color as able.

**Gifted** - SW add additional furniture, accessories and details beyond the required amount.

### **Checklist of 6 items for each class:**

- 1 - Completed practice on (2) hallway worksheets.
- 2 - Completed mood board planning worksheet.
- 3 - Created a bedroom drawing with walls, floor, ceiling and vanishing pt.
- 4 - Drew a bed, window, and 1 piece of additional furniture.
- 5 - Included 3 or more personal objects of identity.
- 6 - Used color in bedroom drawing.

### **4 Point Rubric**

#### **Based on checklist for each student:**

- 4 - All 6 items on checklist were completed and exceptional craftsmanship was used.
- 3 - 5 items on checklist were completed. Color was used.
- 2 - 4 or less items on checklist were completed or no color was used.
- 1 - No evidence of a dream bedroom was drawn.

### **4 Point Rubric for 1 pt. Perspective**

#### **Student demonstrated:**

- 4 - an exceptional understanding of perspective through the bedroom and furniture drawings.
- 3 - a reasonable understanding of perspective with furniture and room mostly going back to the vanishing point.
- 2 - a lack of understanding of perspective with drawing elements mainly not going back to the vanishing point.
- 1 - No understanding or reasonable attempt at perspective.

**Canva**

**Presentation**

# DREAM BEDROOM PROJECT



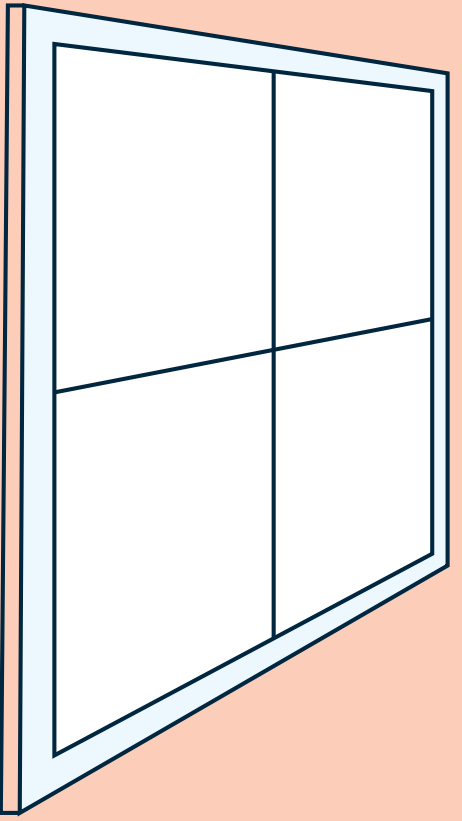

**AN INTERIOR DESIGNER HAS BEEN HIRED TO  
CREATE YOUR DREAM BEDROOM FROM  
YOUR DESIGN PLANS!**

**YOU WILL DRAW A BEDROOM IN ONE-POINT  
PERSPECTIVE WITH THE FOLLOWING:**

**Window  
Bed**

**(1) piece of furniture  
(3) personal objects**

# STUDENT EXAMPLES FROM MISS CUSHWA

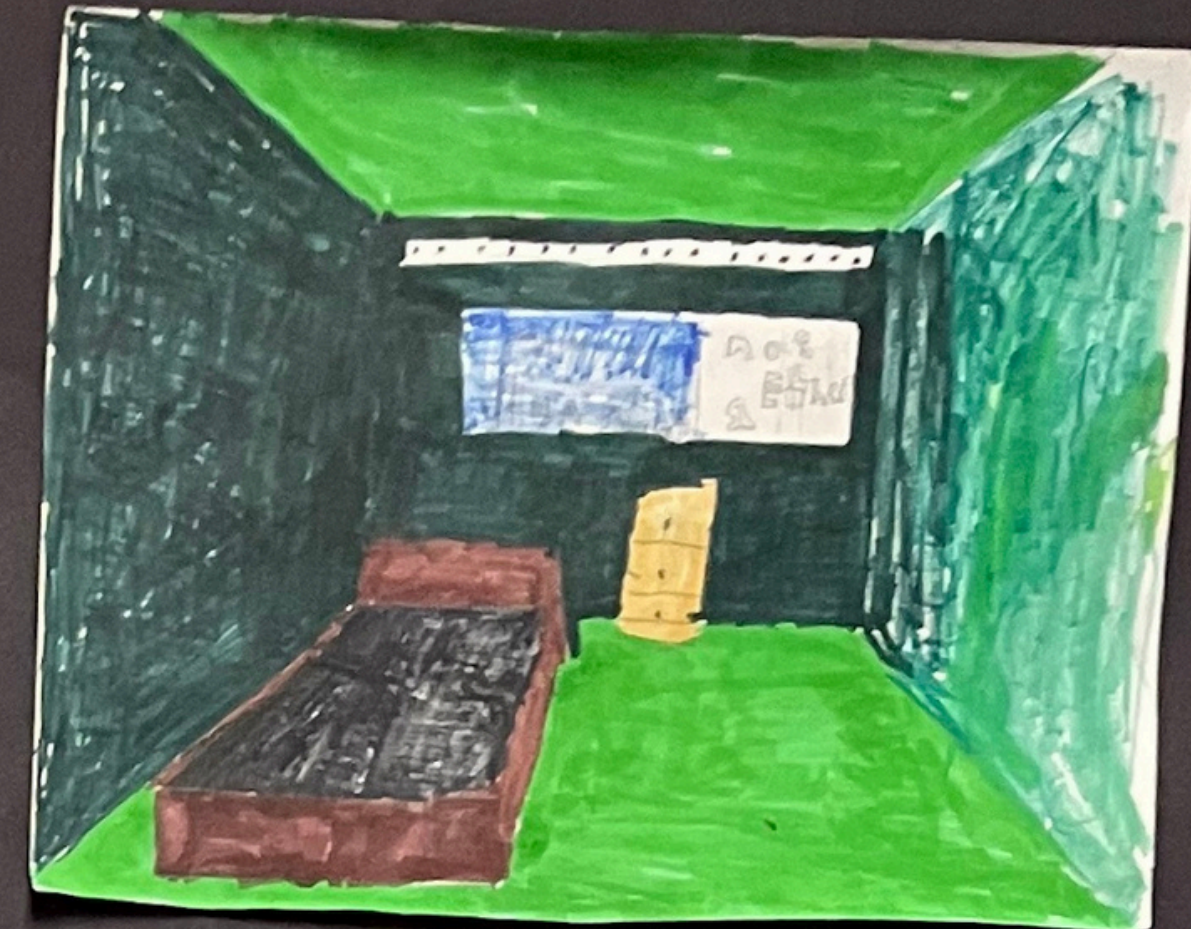
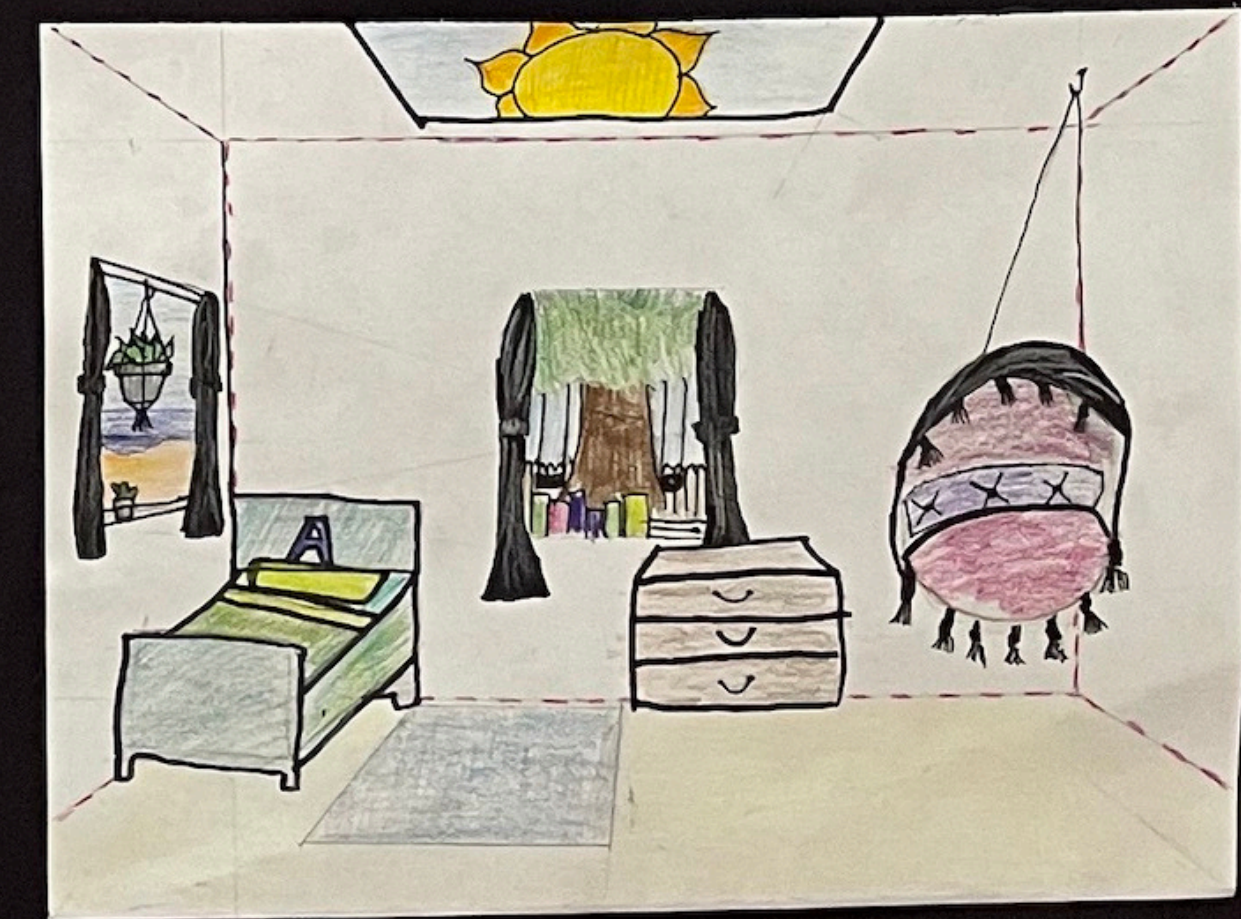
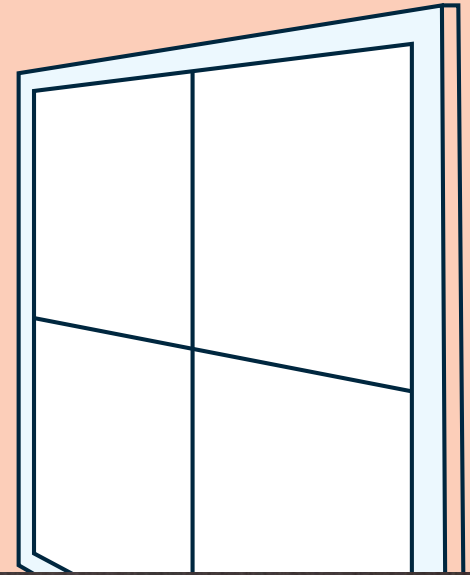
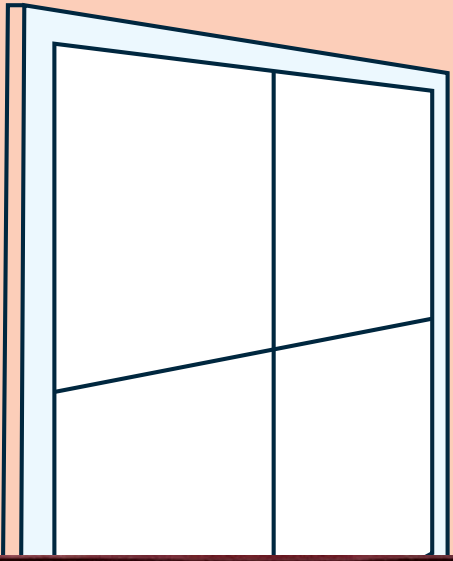
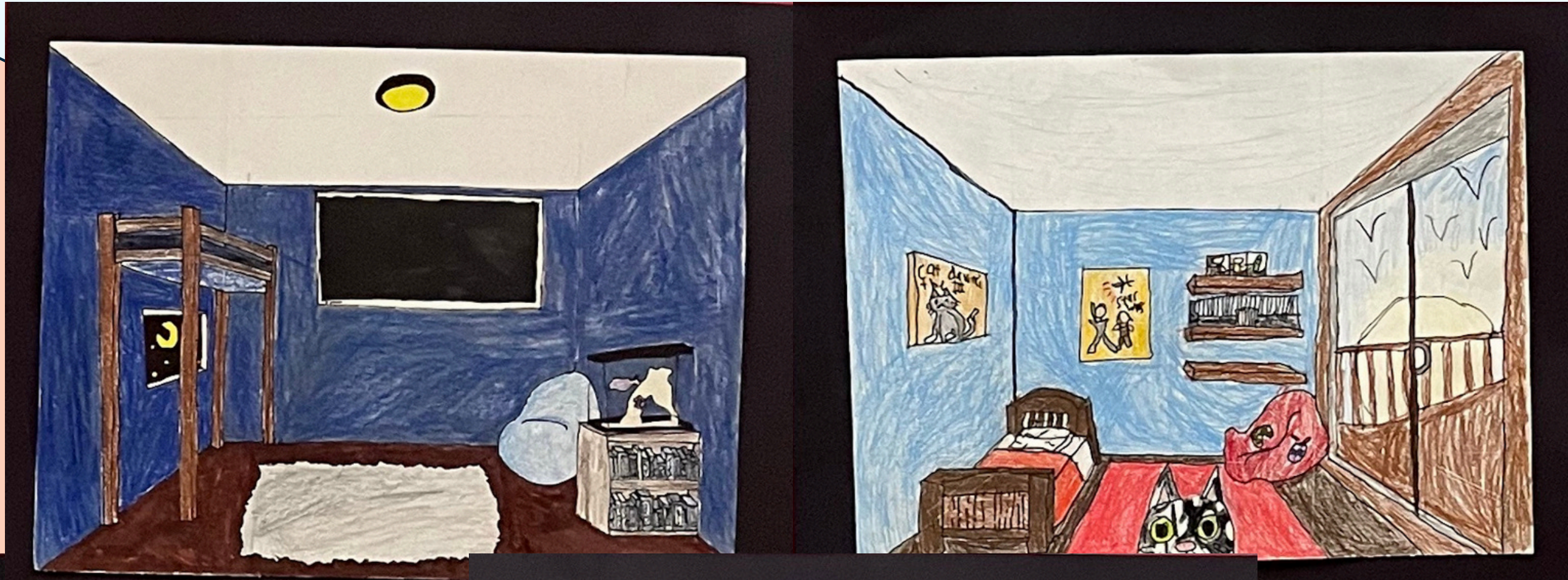

# WE WILL LEARN 1-POINT PERSPECTIVE TO MAKE A BEDROOM LOOK 3-D LIKE THIS PICTURE

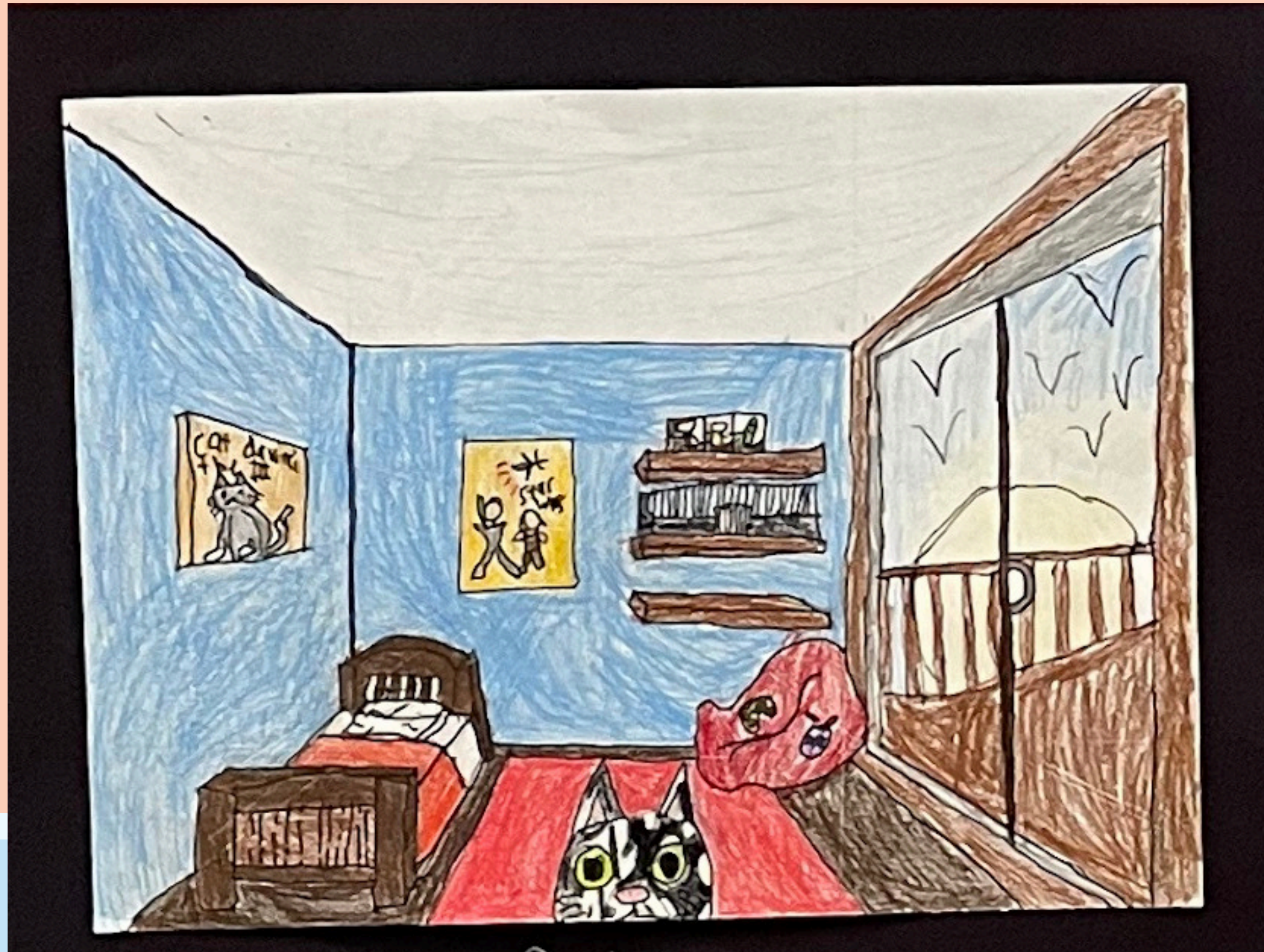

# PERSPECTIVE DRAWING



Perspective drawing is an artistic technique used to create the illusion of depth and three-dimensional space on a flat, two-dimensional surface, like paper or a canvas.

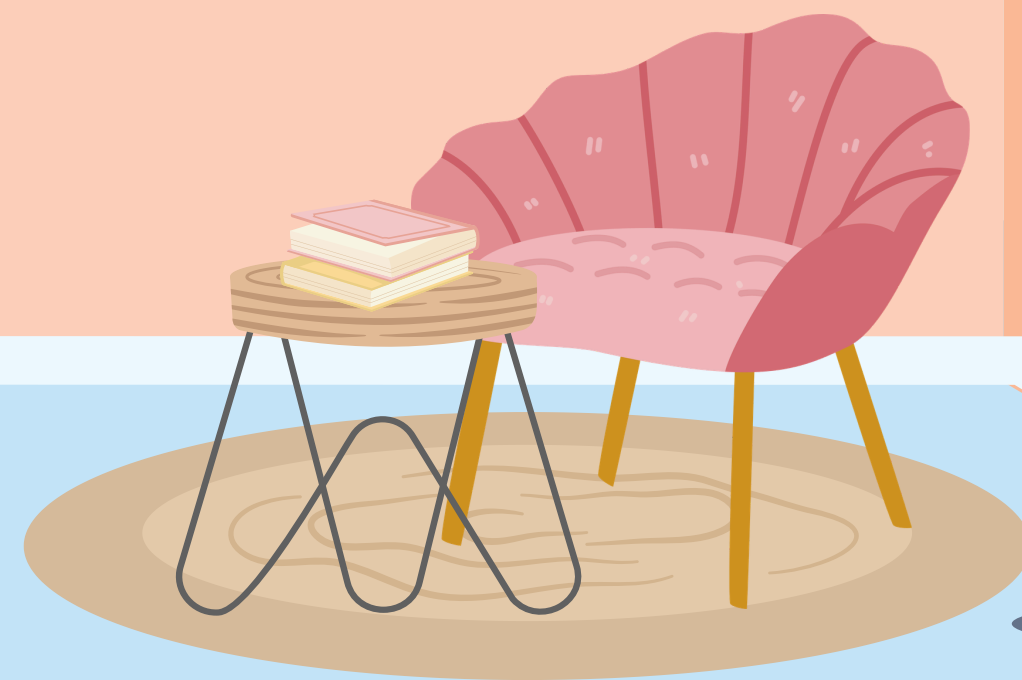



## One-Point Perspective (Parallel Perspective)

- \* Uses one vanishing point on the horizon line.
- \* It is used when the viewer is looking straight on at a flat side of an object

# KEY CONCEPTS



horizon line

vanishing point

orthogonal lines

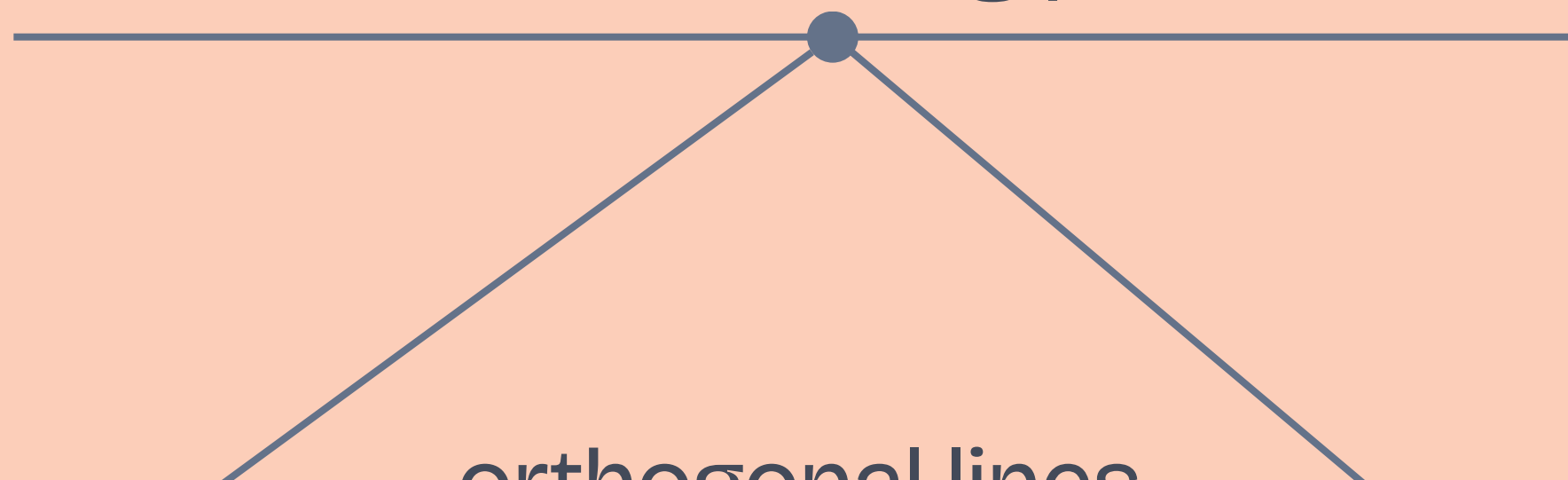
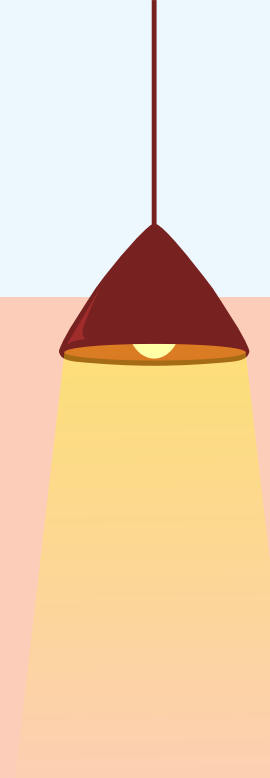

# VAN GOGH'S BEDROOM IN 1 PT. PERSPECTIVE



Vincent van Gogh. The Bedroom, 1889. The Art Institute of Chicago, Helen Birch Bartlett Memorial Collection.

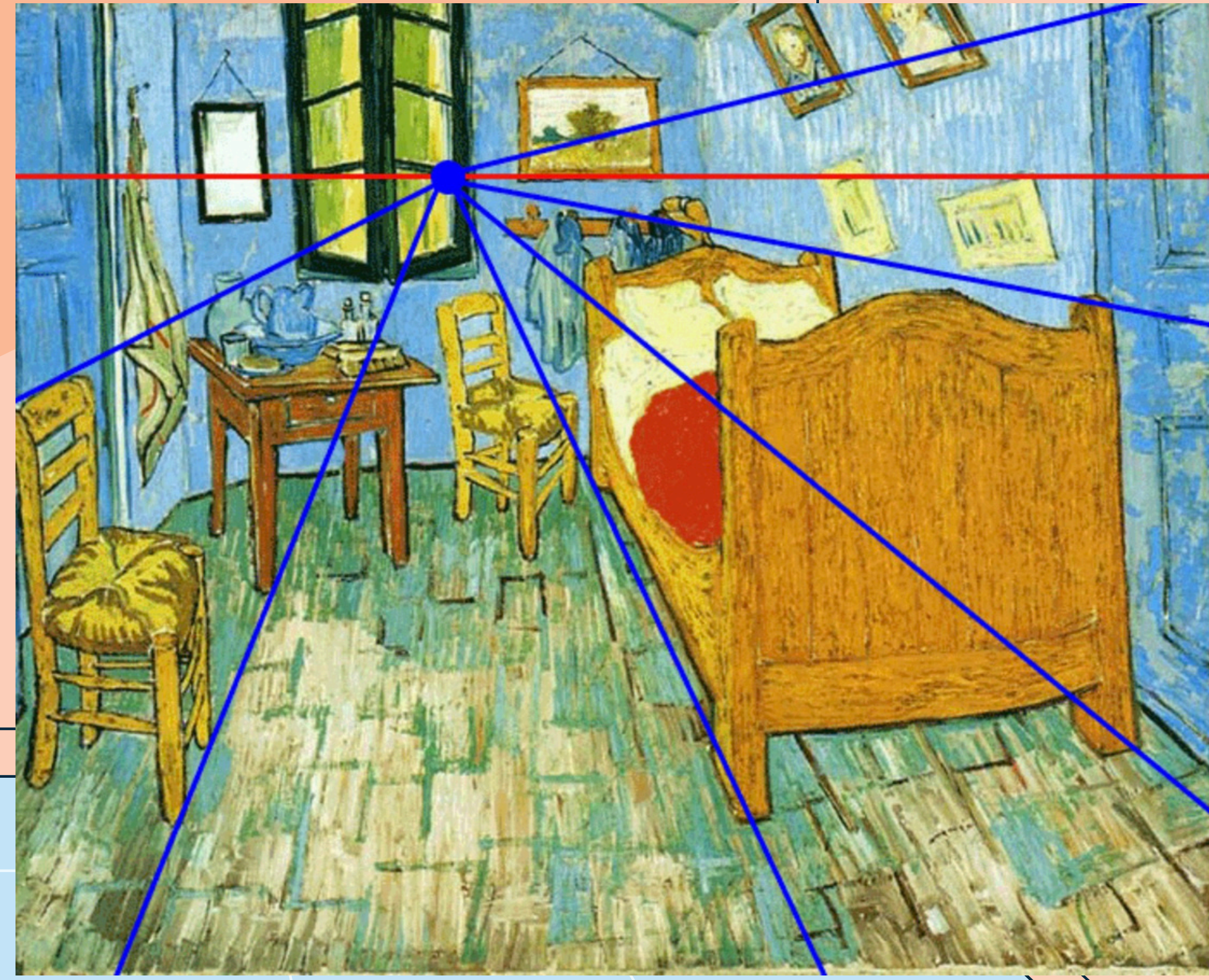

Vincent van Gogh. The Bedroom, 1889. with orthogonal lines



## Practice and Planning your Dream Bedroom

- \* Use a ruler and pencil to find and draw the horizon line, vanishing point, and orthogonal lines in your school.
- \* Use the Mood Board worksheet to plan your Dream Bedroom!

# DO THESE FIRST

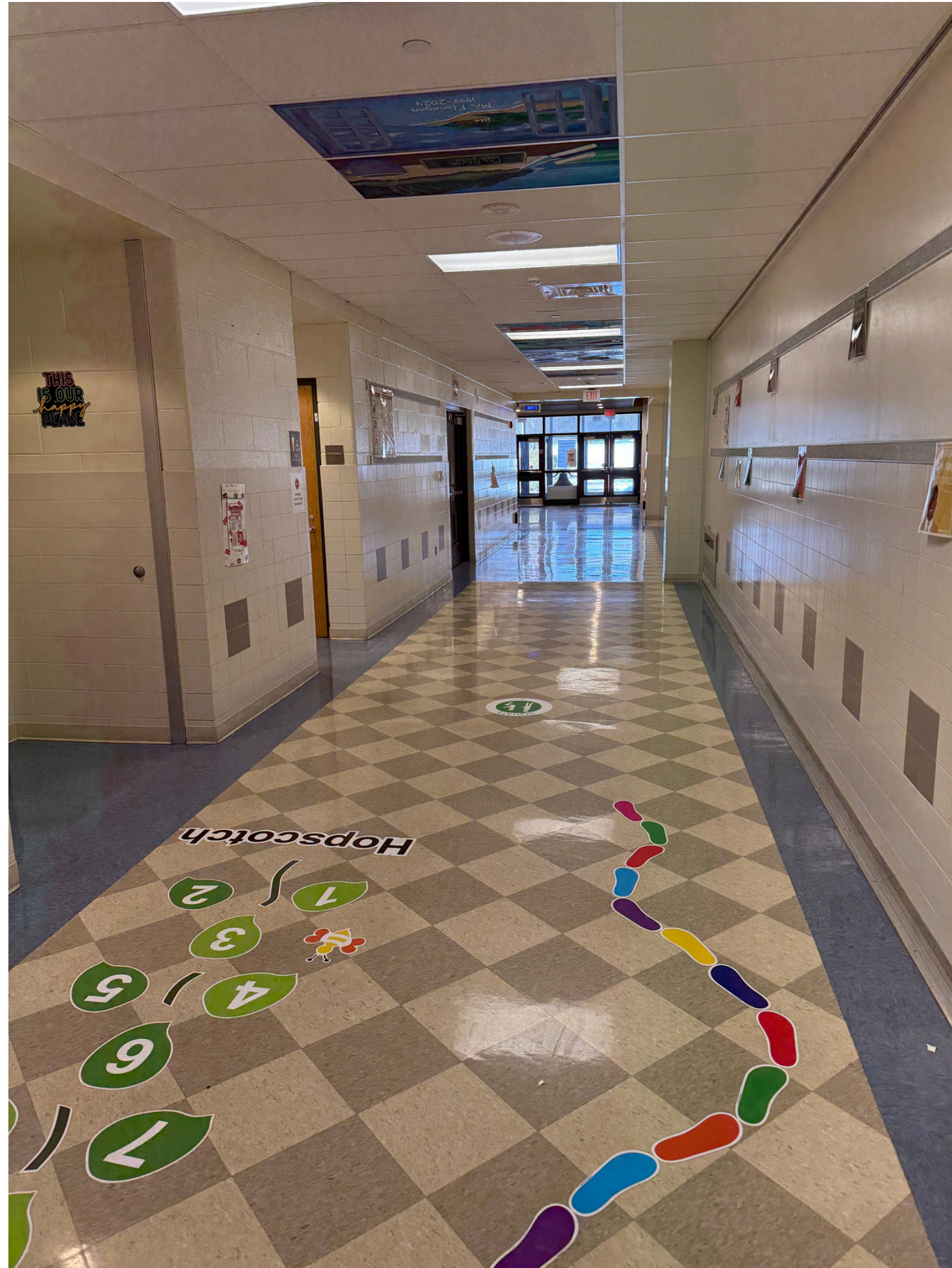

# BLANK SHEET

## DREAM BEDROOM MOOD BOARD

**Color Scheme**

**Lighting Fixtures**

**Textures/Patterns**

**Finishes for Walls**

**HOW CAN MY BEDROOM REFLECT MY IDENTITY?**

**Flooring Options**

**Accessories/Decor**

**Accessories/Decor**

**Accessories/Decor**

**BED DESIGN**

**WINDOW**

**FURNITURE PIECE**

# Mrs. SANDERS' PLAN

## DREAM BEDROOM MOOD BOARD

**Color Palette**

**Lighting Fixtures**

**Bedding**

**Walls (texture, color, wallpaper, pattern etc)**

**HOW CAN MY BEDROOM REFLECT MY IDENTITY?**

**Flooring Options**

**Object/Decor**

**Object/Decor**

**Object/Decor**

**BED DESIGN**

**WINDOW**

**FURNITURE PIECE**

# Mrs. SANDERS' NEW YORK CITY DREAM BEDROOM DRAWING

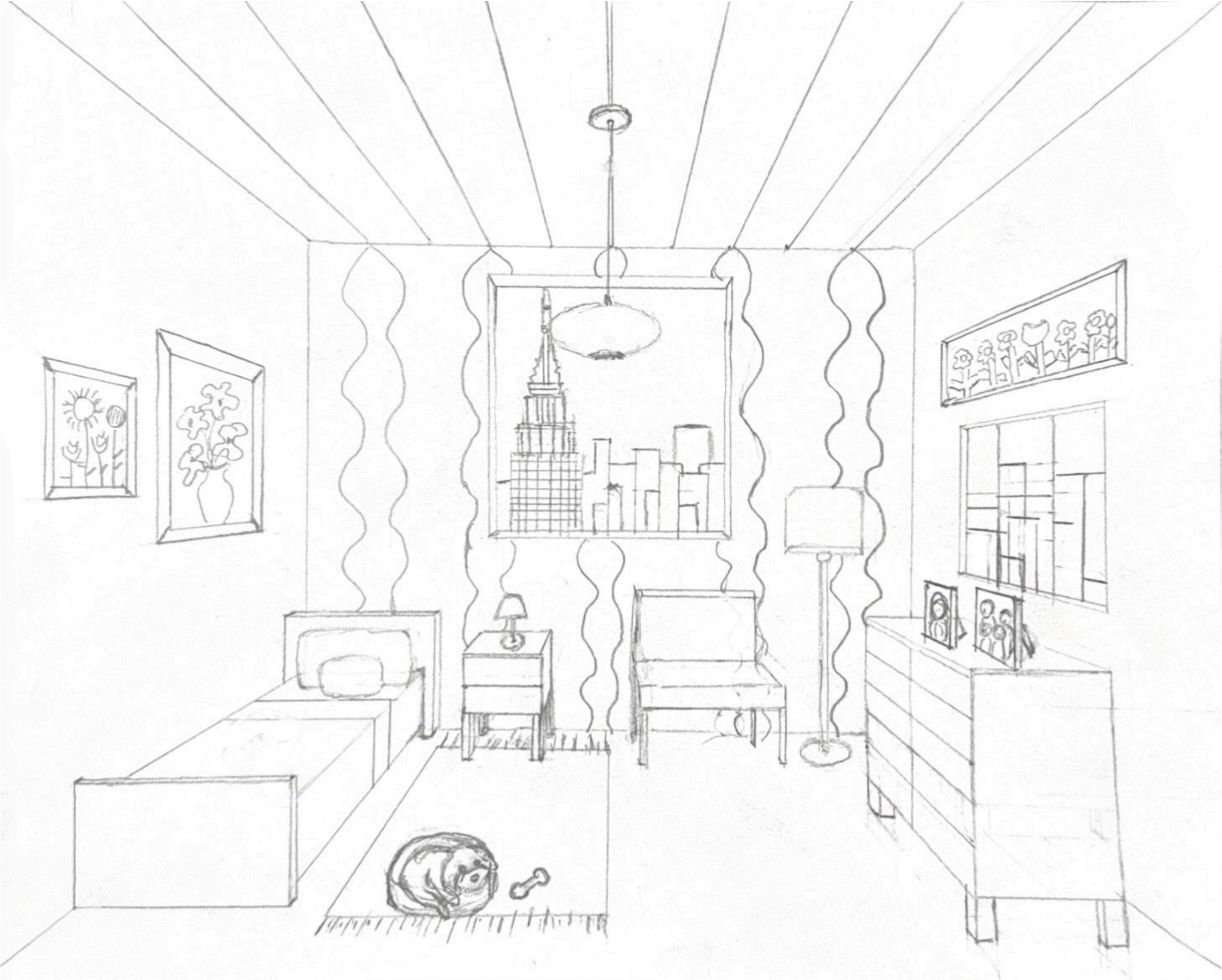

# Mrs. SANDERS' NEW YORK CITY DREAM BEDROOM IN COLOR



# Horizon Line, Vanishing Point and Orthogonal Lines shown

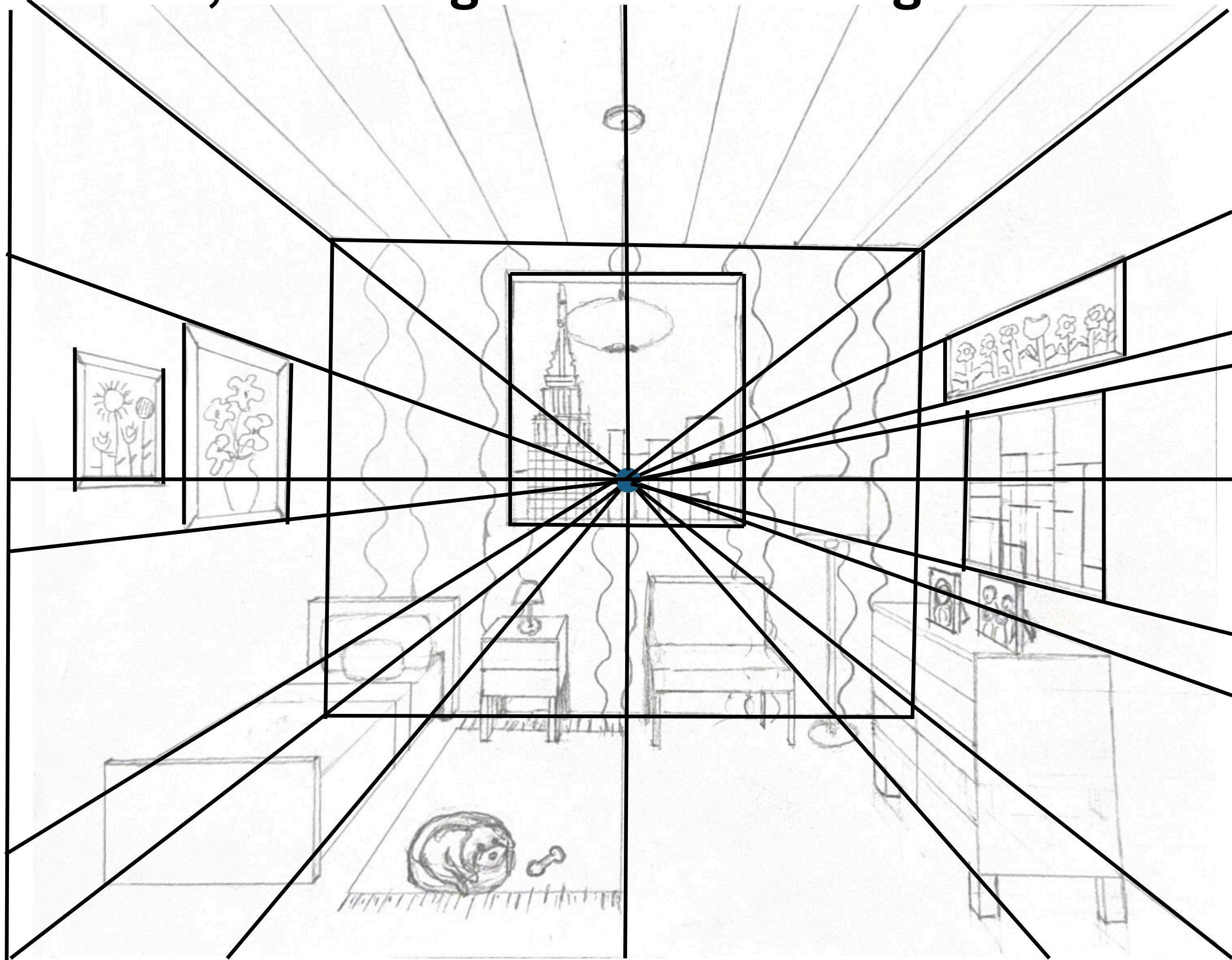

# DEMO SLIDE TO PROJECT ON THE WHITE BOARD

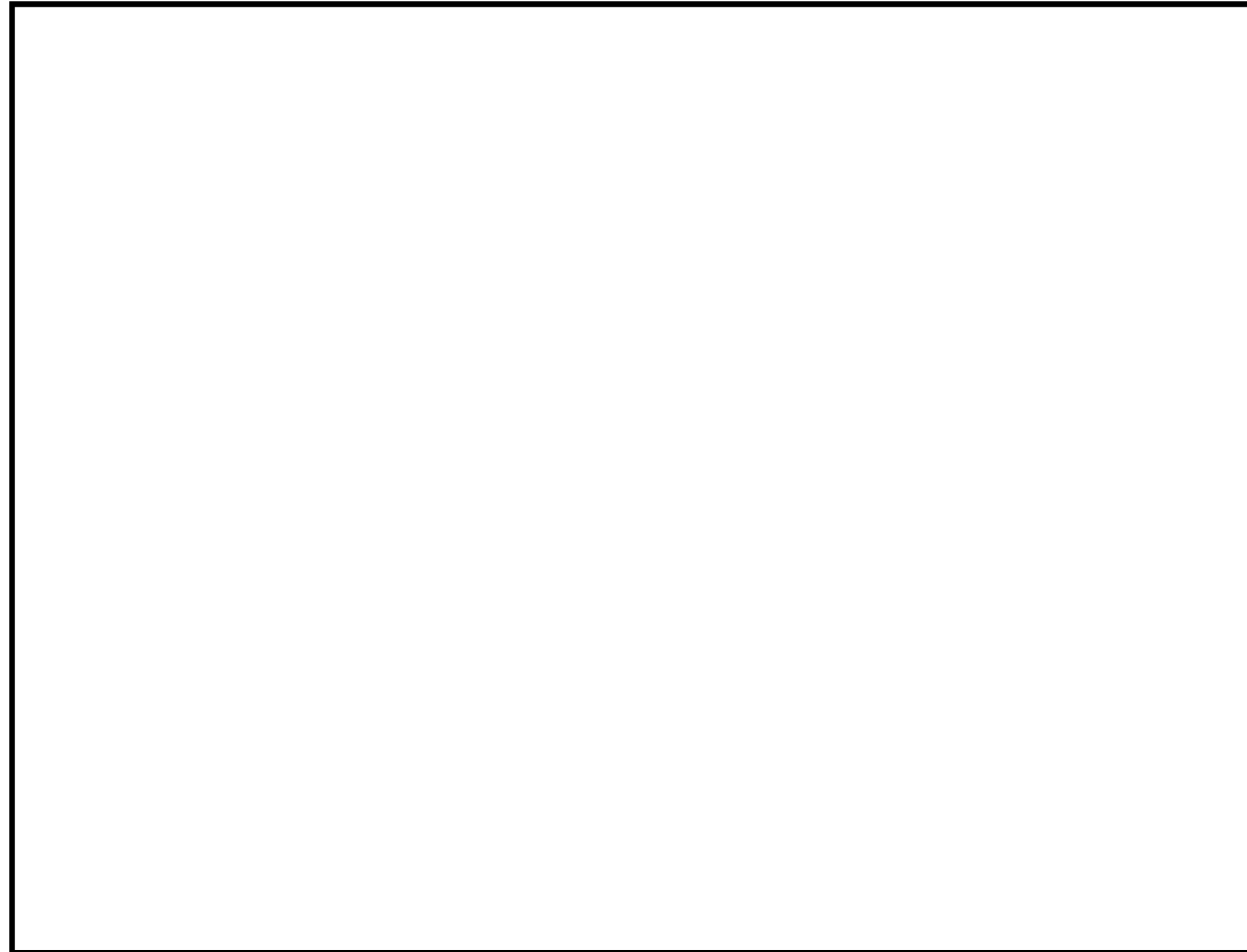

**Co-Operating Teacher,  
Miss Cushwa's  
resource packet for  
student reference**

# Draw a Bedroom

## IN ONE POINT PERSPECTIVE

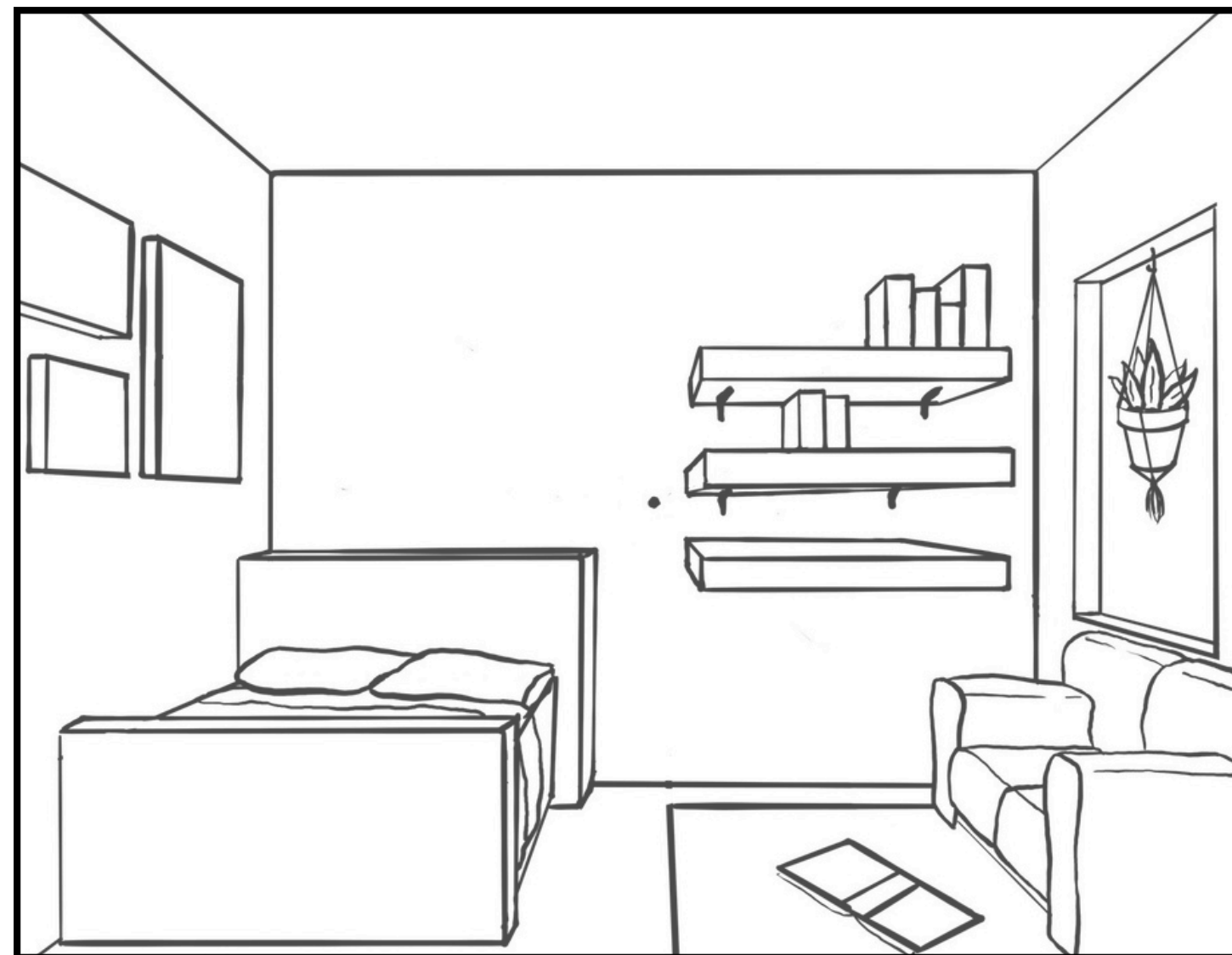

## STEP ONE: WALLS AND WINDOW

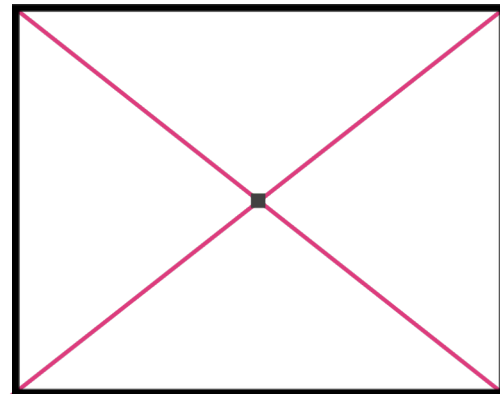

Draw an X by connecting the corners with diagonal lines. Where the lines intersect, mark the vanishing point!

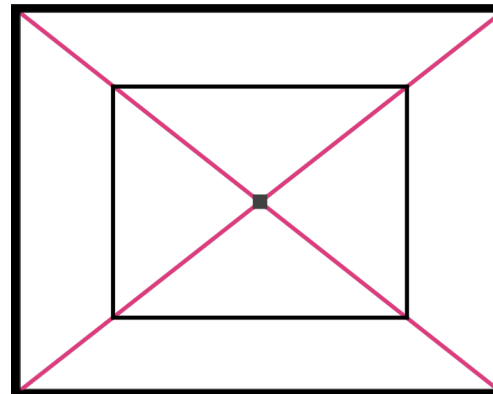

Use your ruler to draw a rectangle, connecting the lines between the X you made in step one.

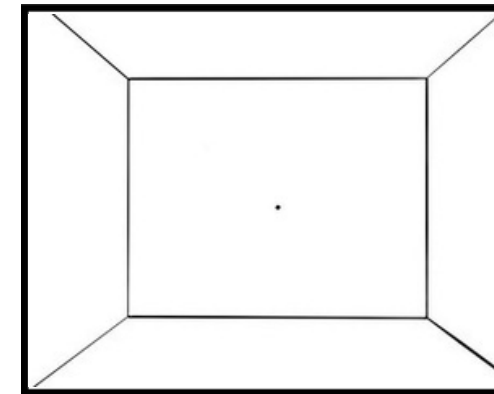

Erase the lines inside the rectangle, making sure to leave your vanishing point

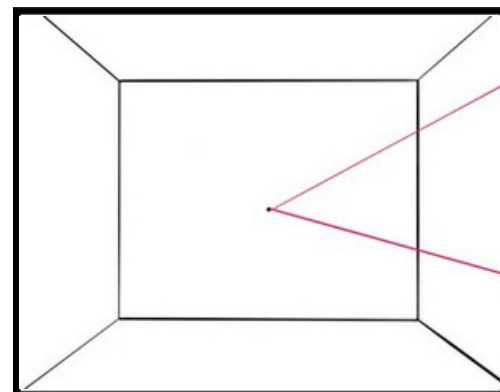

Draw a line from the vanishing point to the top of your window, and another to the bottom of your window

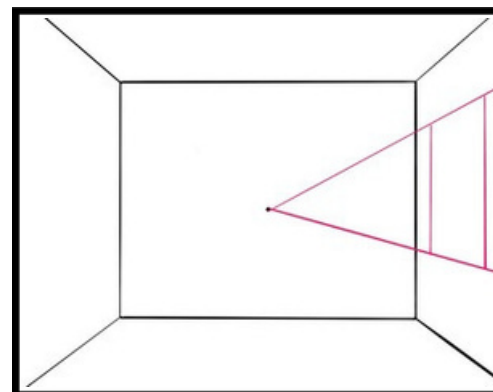

Use **vertical lines** to draw the left and right edges of your window

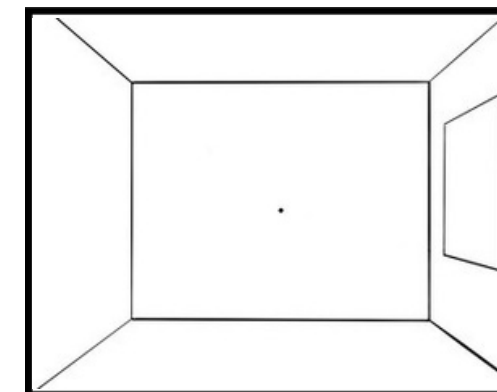

Erase the lines outside of the window

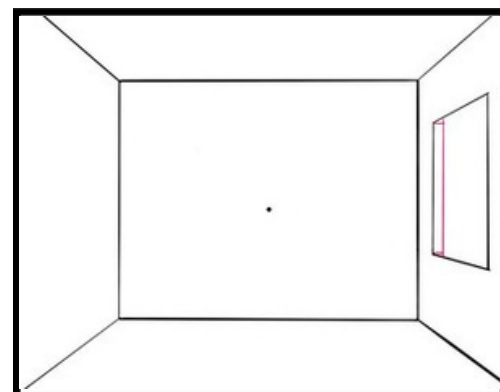

Use another vertical line to create depth in the window

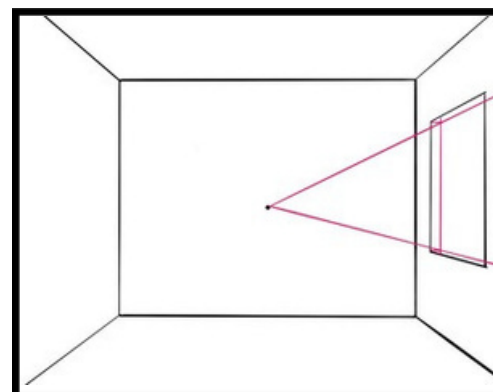

Use lines from the vanishing point to add depth to the top and bottom of the window

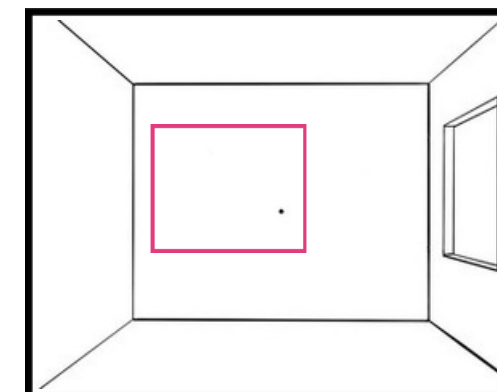

If you want to add a window to the back wall use horizontal and vertical lines.

Repeat the same steps to create windows on the opposite wall, or a skylight or trap door.

## STEP TWO: RUG AND BED

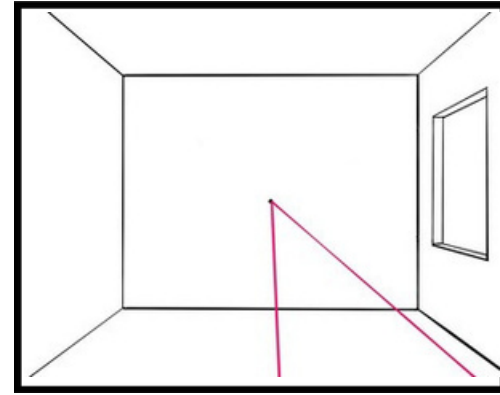

To create a rug, draw lines from the vanishing point to the edges of your rug

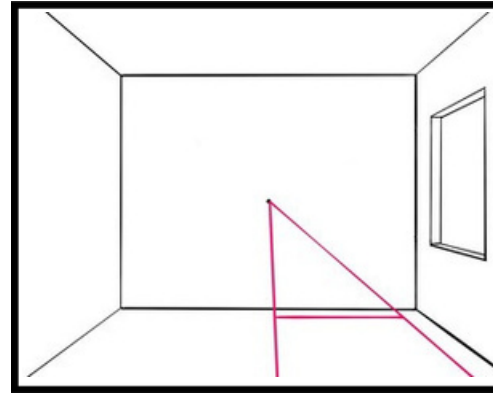

Use a horizontal line to draw where the rug ends

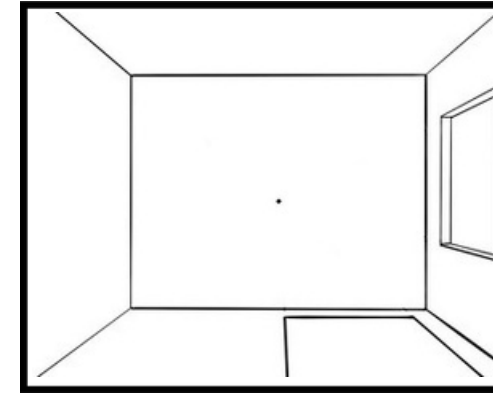

Erase the extra lines to leave just the rug

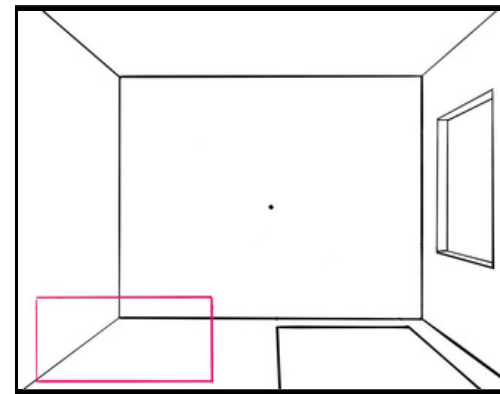

Start your bed with a rectangle on the floor

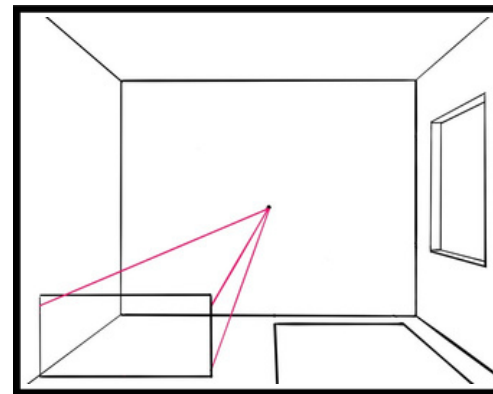

Draw lines for the top and sides of the mattress back to the vanishing point

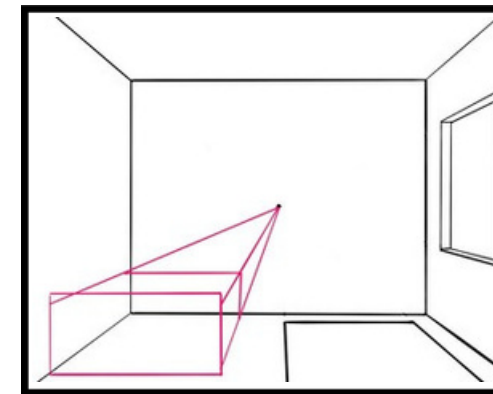

Use a horizontal and vertical line to end your mattress

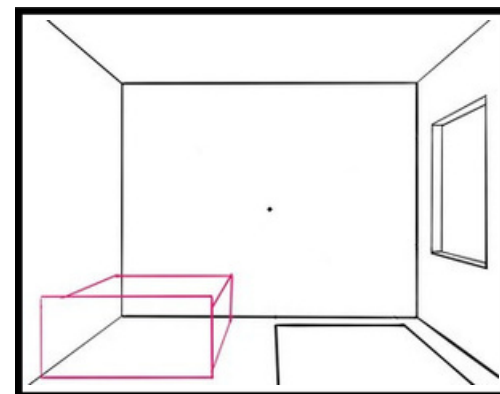

Erase the extra lines to leave just the mattress and the foot of the bed

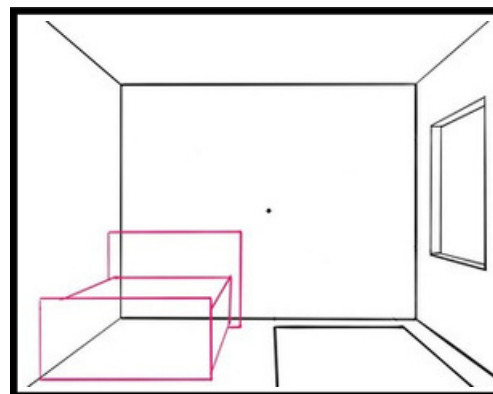

Draw a headboard behind your mattress, making sure it ends on the floor

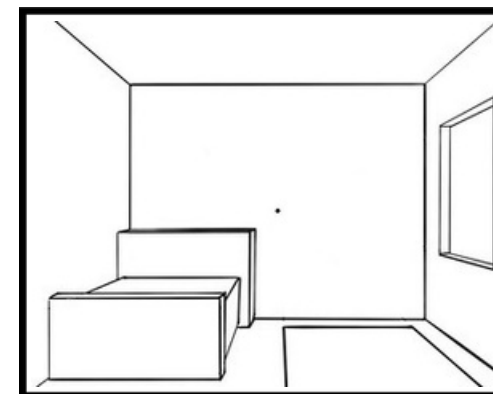

Add depth to the head and foot of your bed by drawing the edges. Make sure the corners point to the vanishing point.

## STEP FOUR: DETAILS AND DECORATIONS

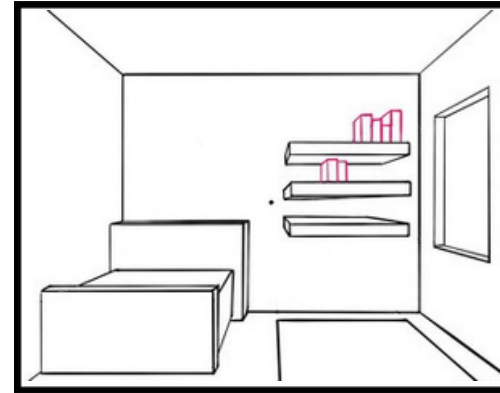

Don't forget to erase extra lines when you are finished!

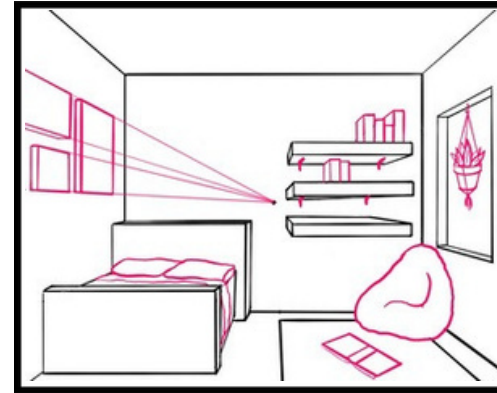

When drawing art and posters on the wall, make sure they also go back to the vanishing point!

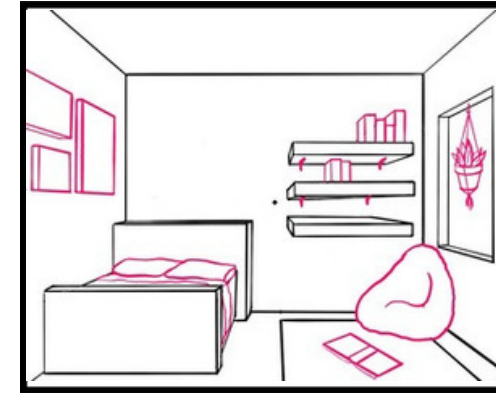

Add details to make your room feel like your own. What is outside the window? On the floor?

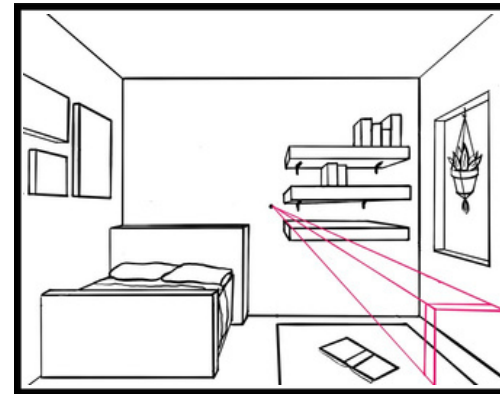

To draw a couch, start with the square end, and measure it back to the vanishing point

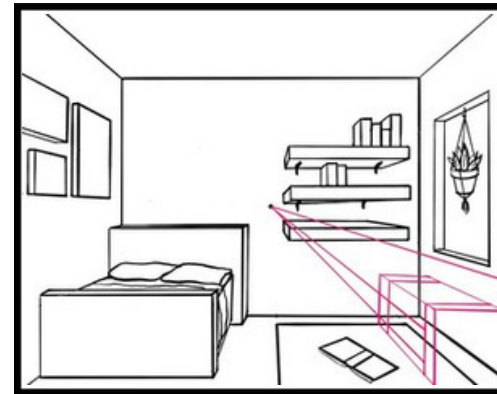

Add the other arm and the back of the couch, also measuring back to the vanishing point

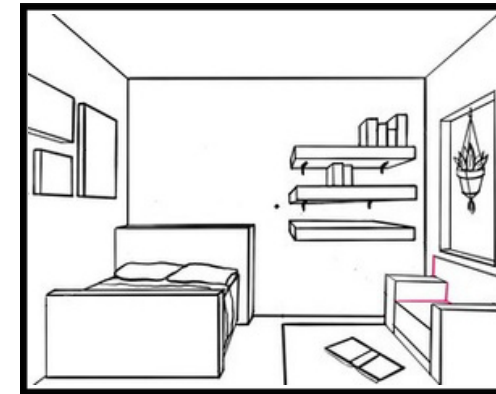

Use horizontal and vertical lines to finish off the shapes of the couch

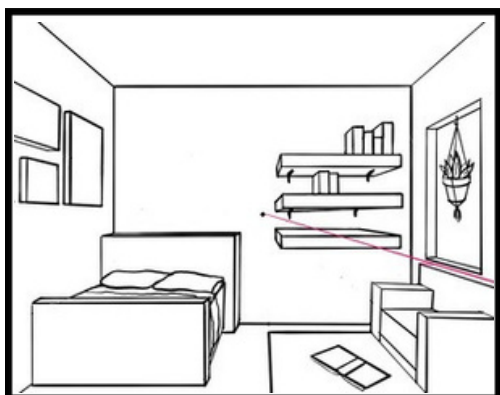

Add dimension to the top of the couch

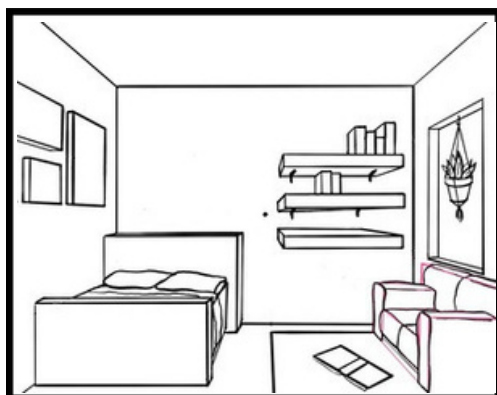

Soften the corners and add curves to make the couch feel soft

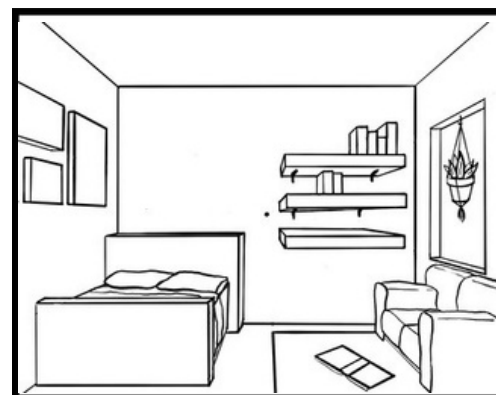

Don't forget to add art to the spaces on the walls, and your own ideas to the shelves!

### STEP THREE: SHELVES

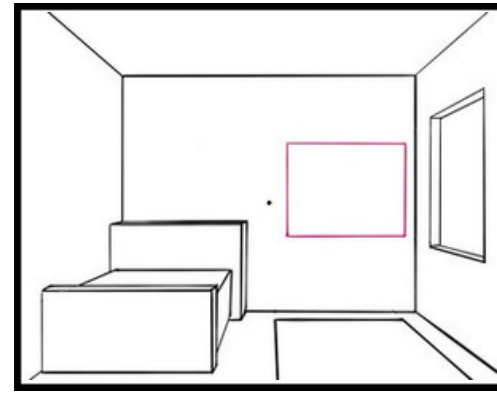

Draw a square or rectangle to mark out your shelves on the wall

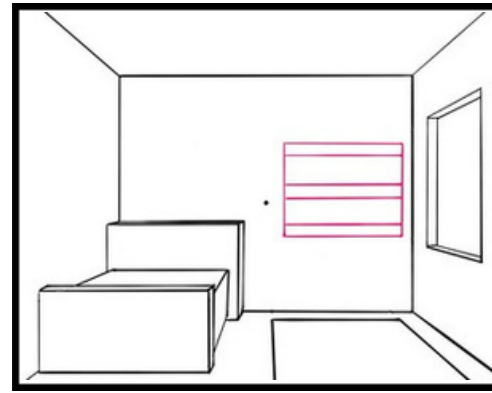

Draw out the front of your shelves

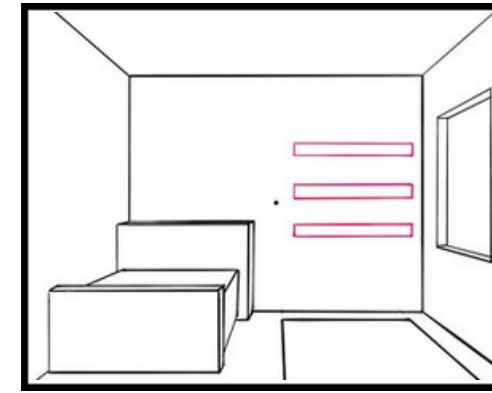

Erase the extra lines

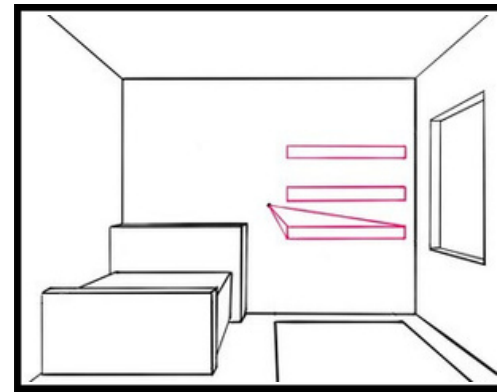

Draw lines from the corners of the bottom shelf, to the vanishing point

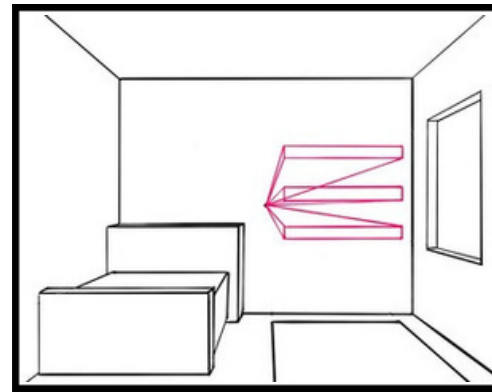

Draw lines from the corners of the top and middle shelf to the vanishing point

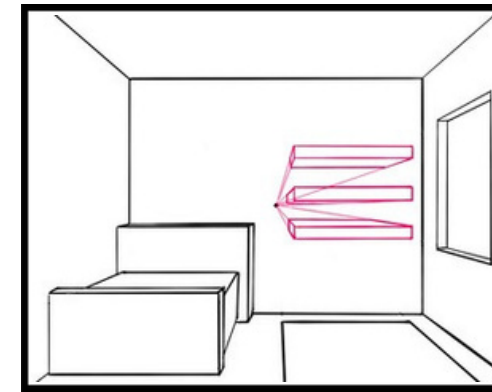

Use horizontal and vertical lines to end the shelves

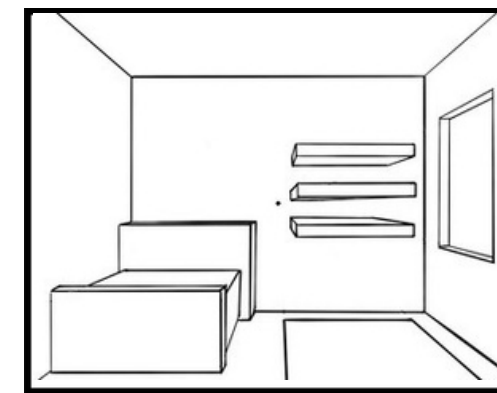

Erase the extra lines to leave floating shelves

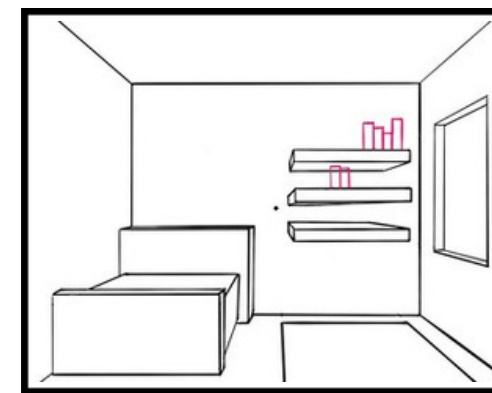

Start books with rectangles on the shelves

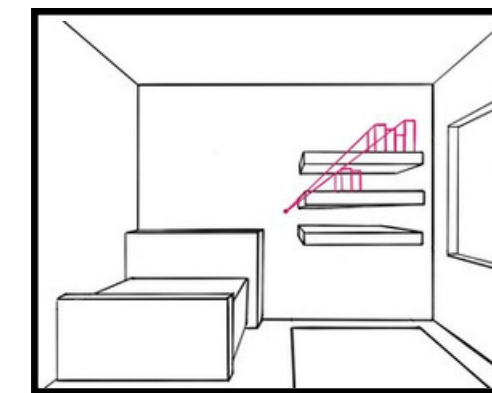

Measure the sides of the books back to the vanishing point



The same object can look different depending on where the vanishing point is.

# Bed

These beds are all drawn by referencing the picture to the left.. Start by drawing the side of the object that is facing you, in this case the end of the bed.

Notice the differences between how the bed looks when it is directly under the vanishing point, compared to when it is drawn to the side of the vanishing point.

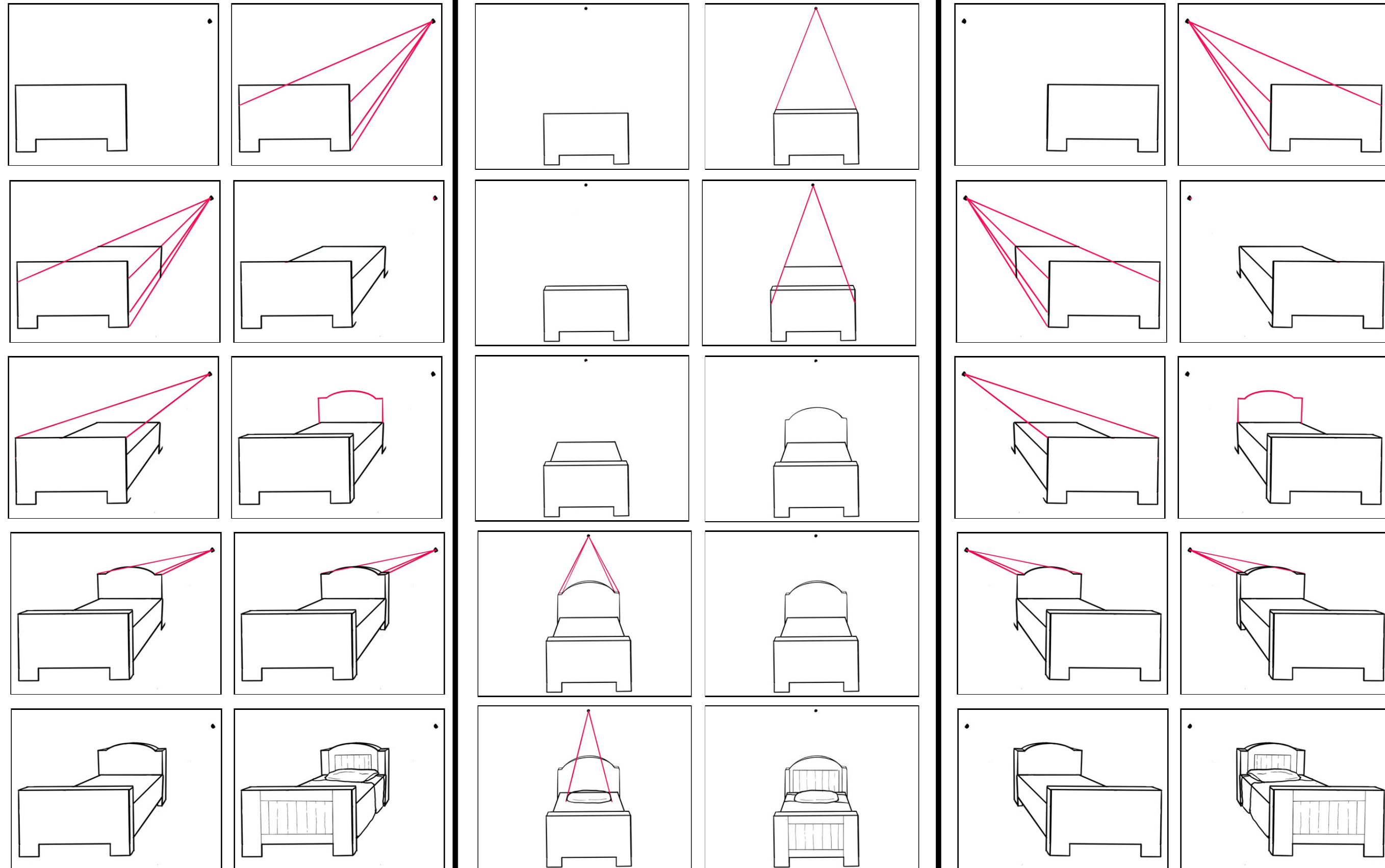

# Bunk Bed

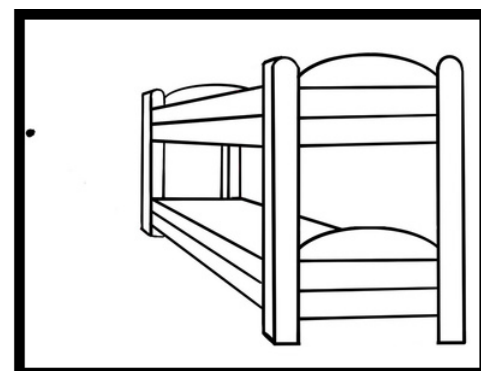
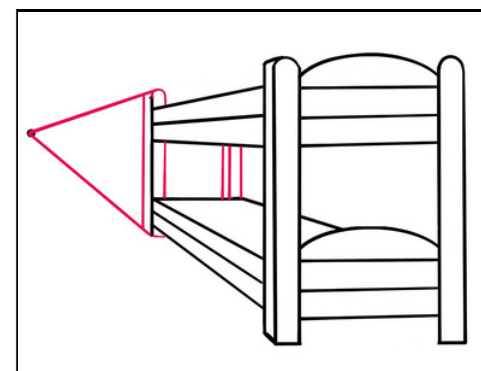
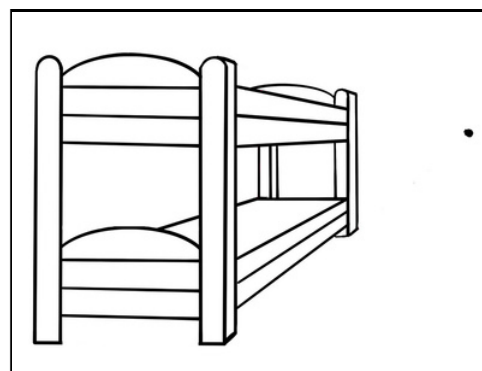
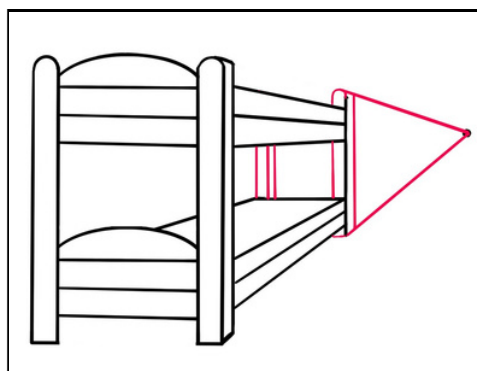
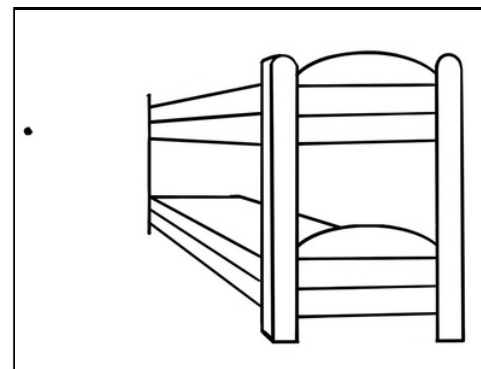
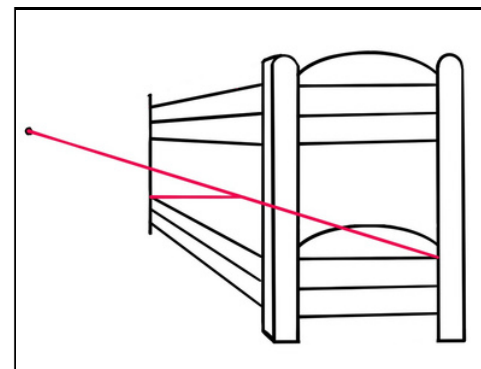
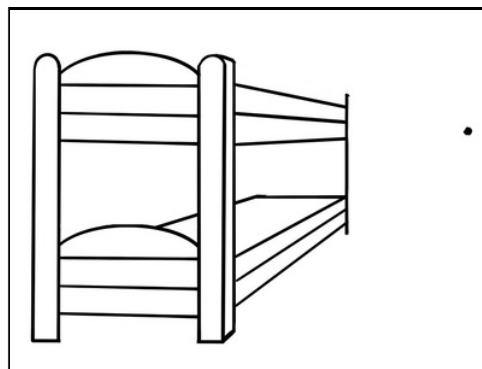
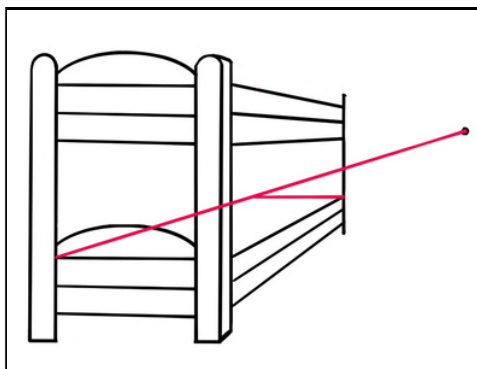
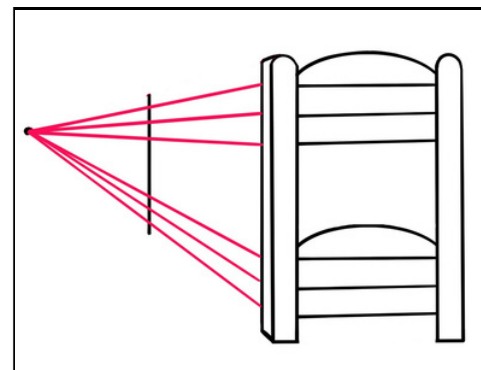
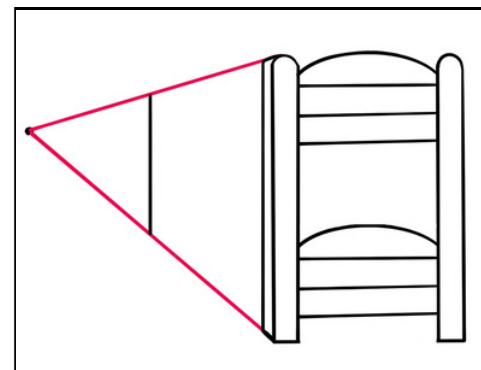
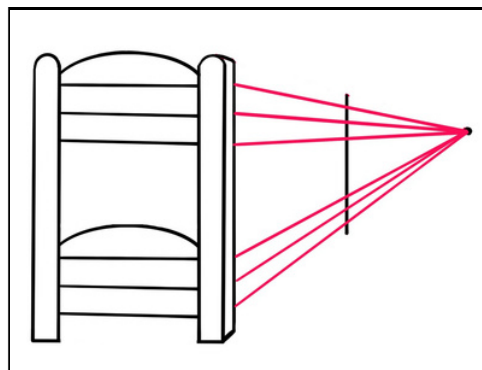
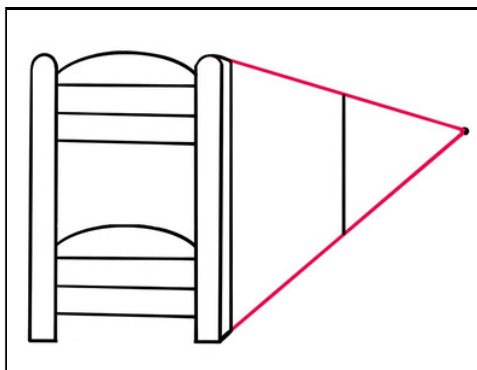
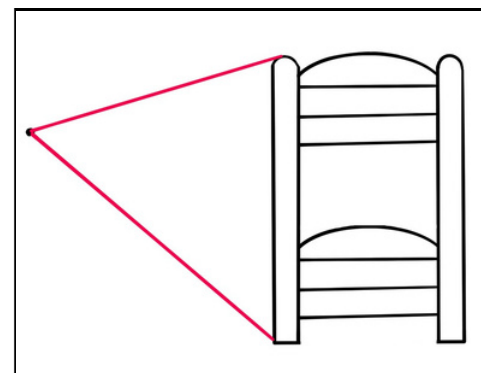
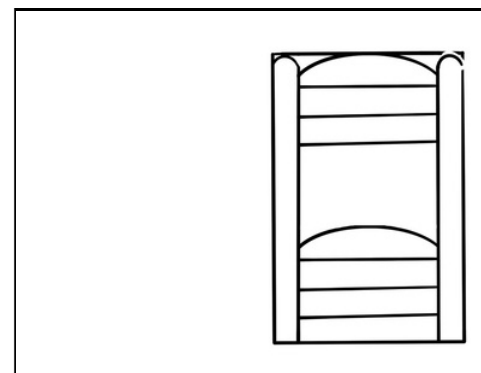
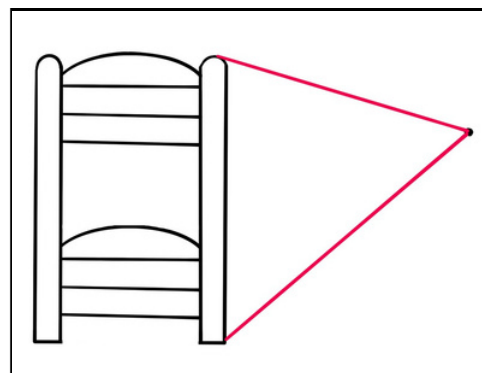
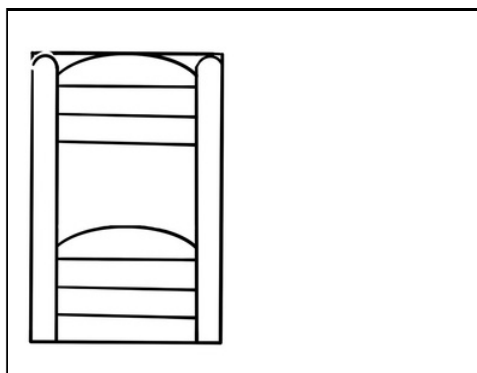
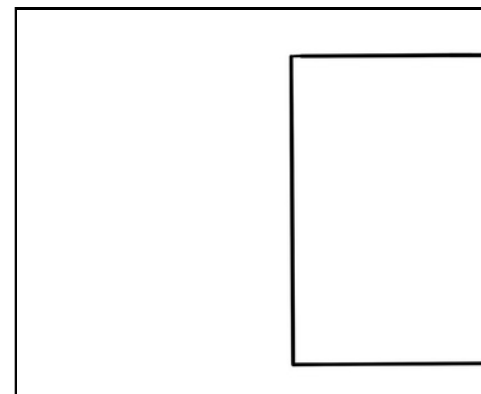
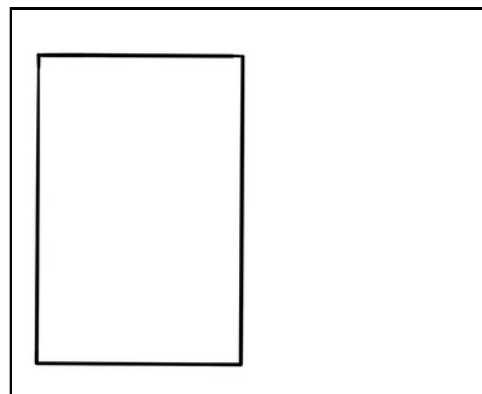

# Disco Ball

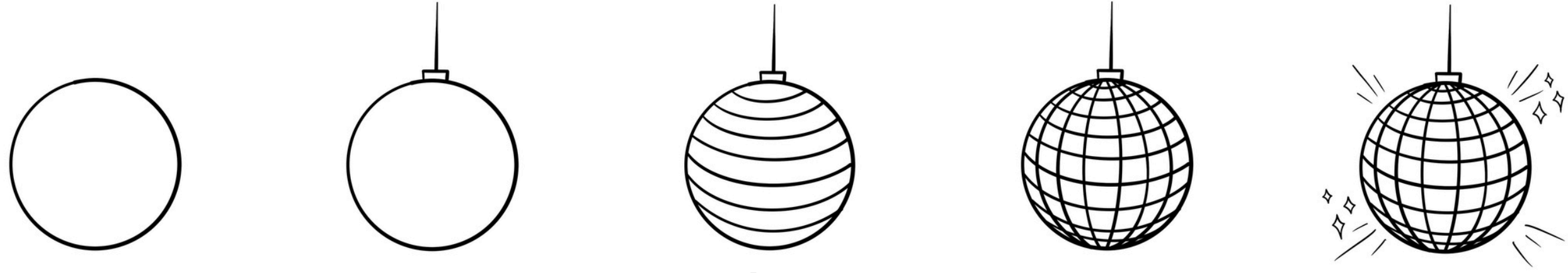

# Fish Tank/Terrarium

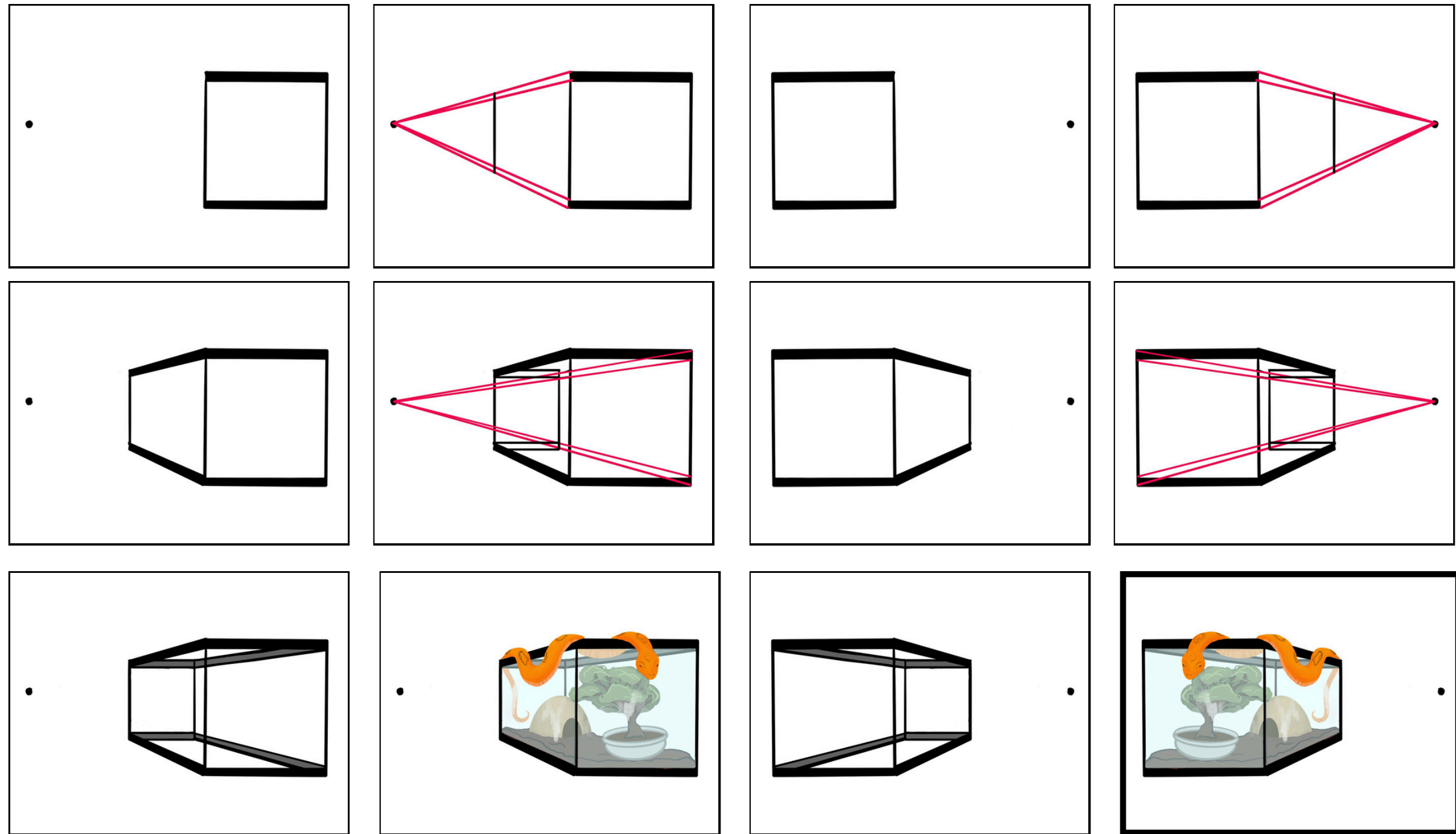

# Table/Desk

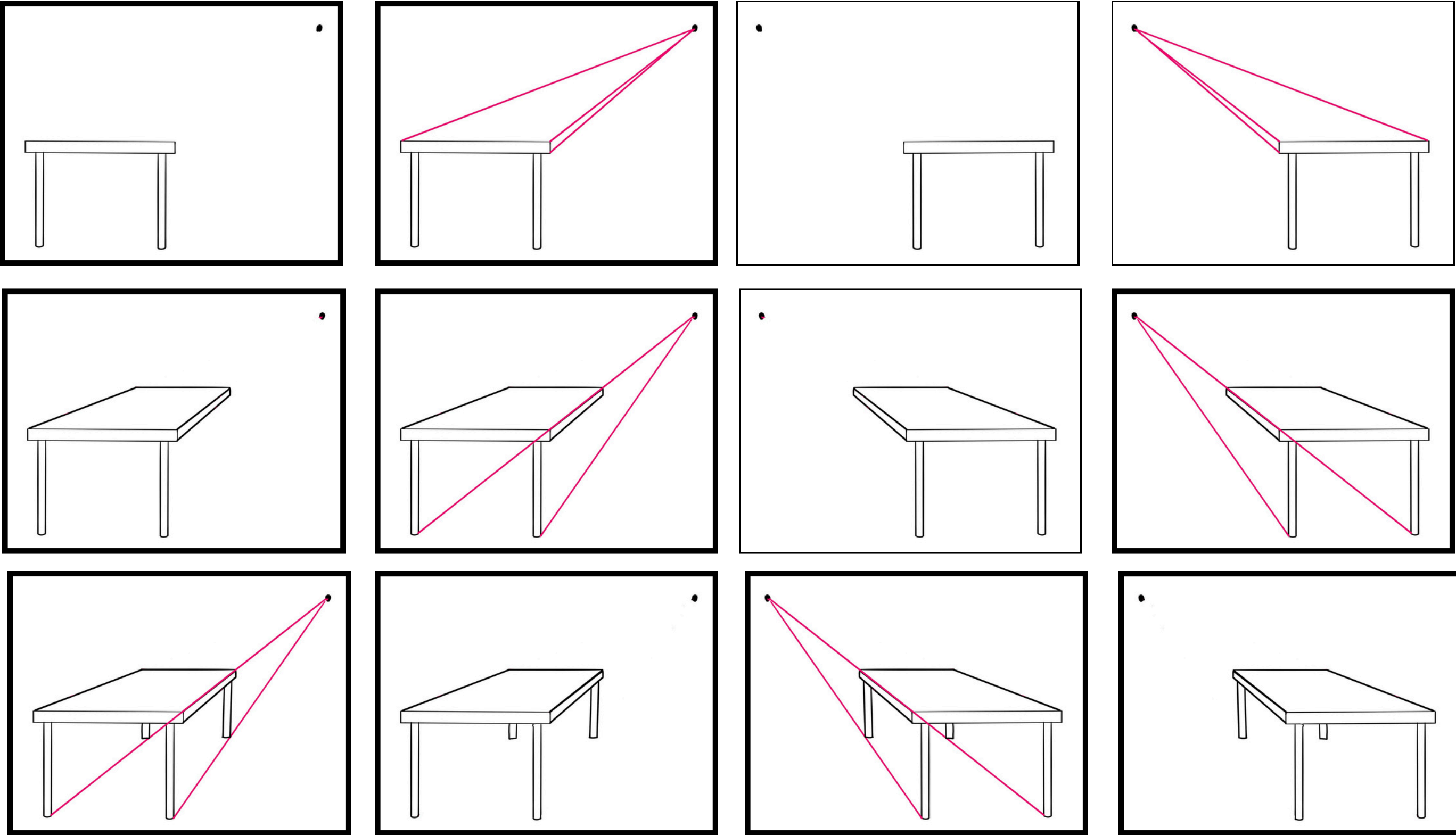

# HALLWAY WORKSHEETS

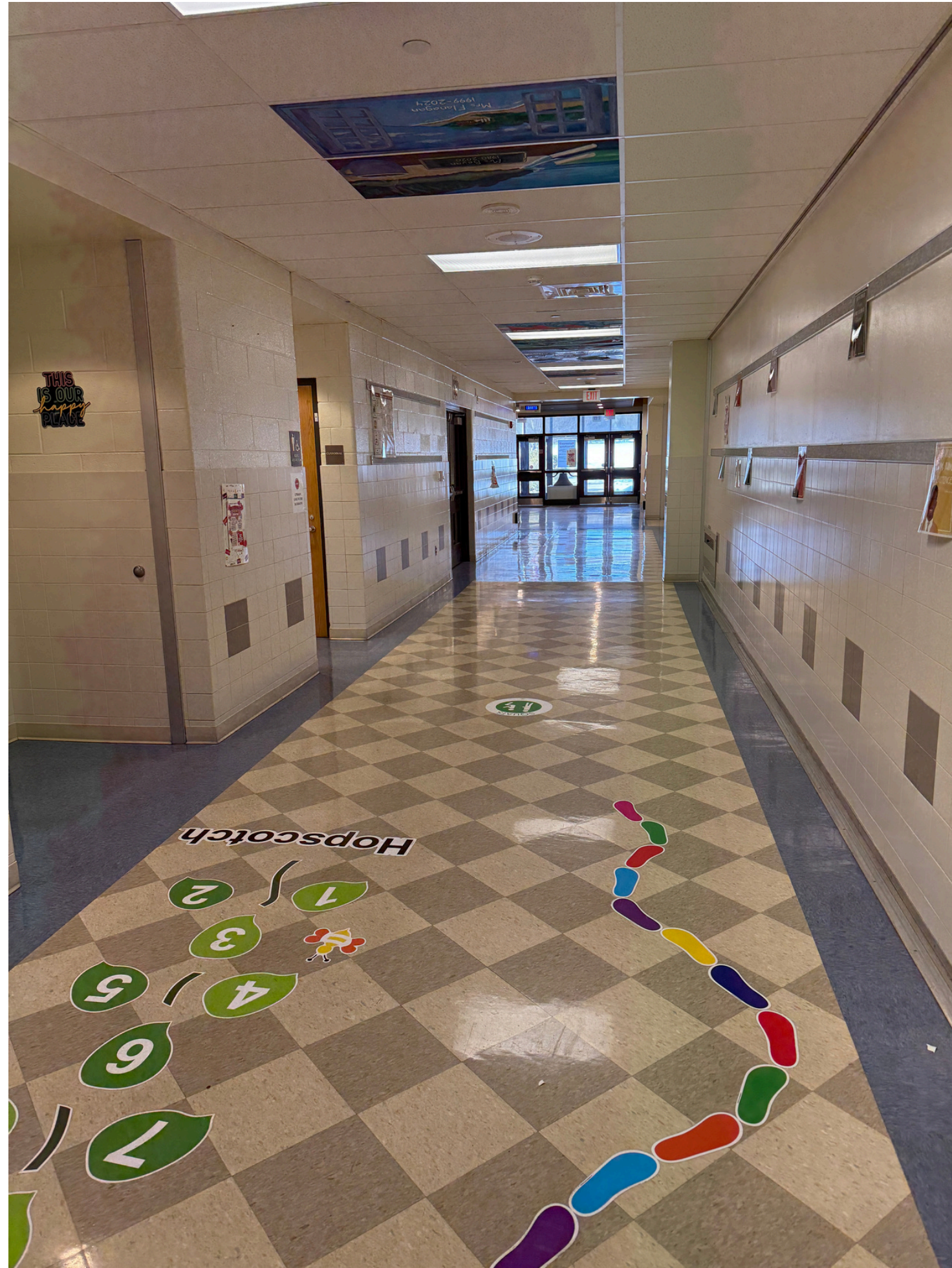

# WORKSHEET

# REFERENCE PHOTOS

## DREAM BEDROOM MOOD BOARD

Color Scheme	Lighting Fixtures	Textures/Patterns	Finishes for Walls

HOW CAN MY BEDROOM REFLECT MY IDENTITY?

Flooring Options	Accessories/Decor	Accessories/Decor	Accessories/Decor

BED DESIGN	WINDOW	FURNITURE PIECE

*(The mood board also includes various decorative icons such as beds, lamps, chairs, and plants.)*

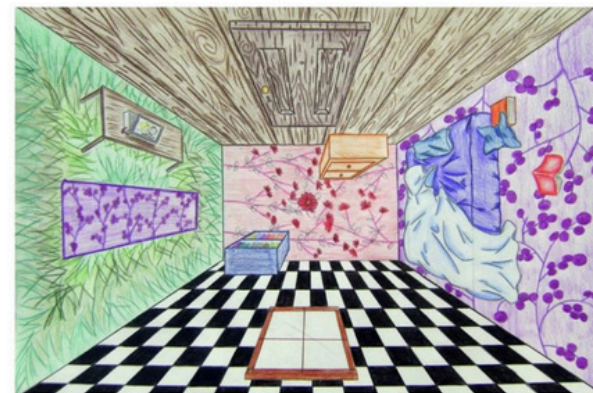
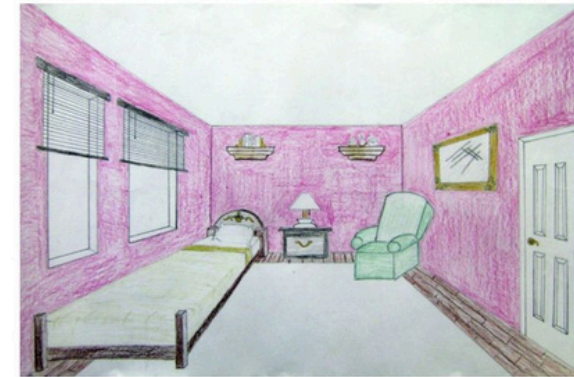
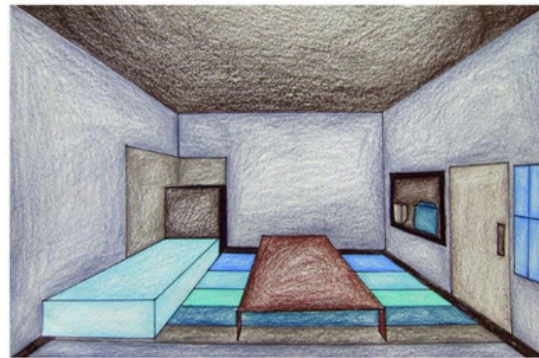
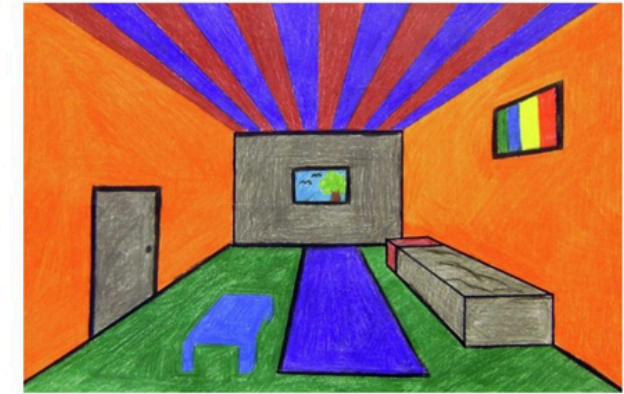
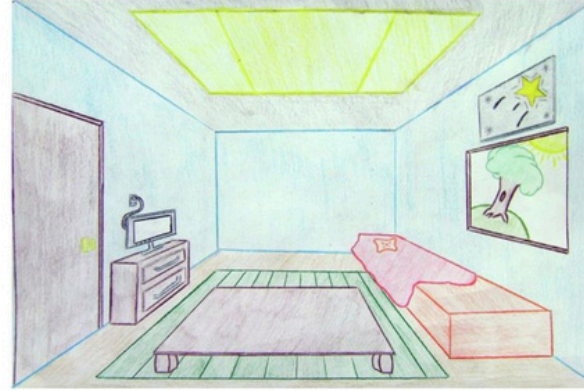

Inspiration Room Pictures

Inspiration Room Pictures

**MODIFICATIONS FOR  
VISUALLY IMPAIRED AND  
MULTIPLE DISABILITIES**

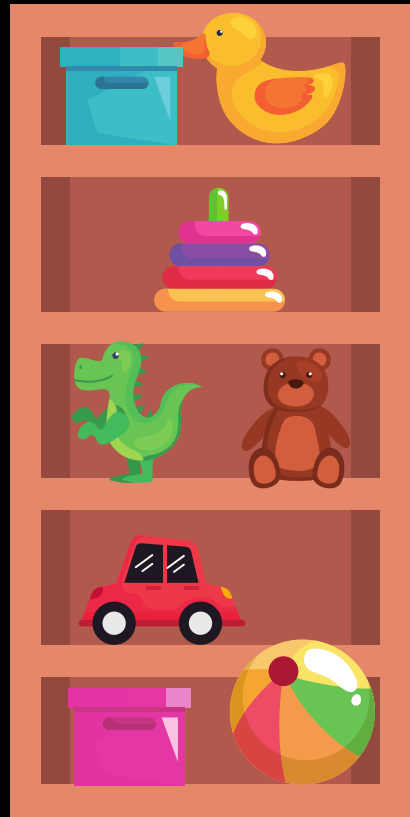

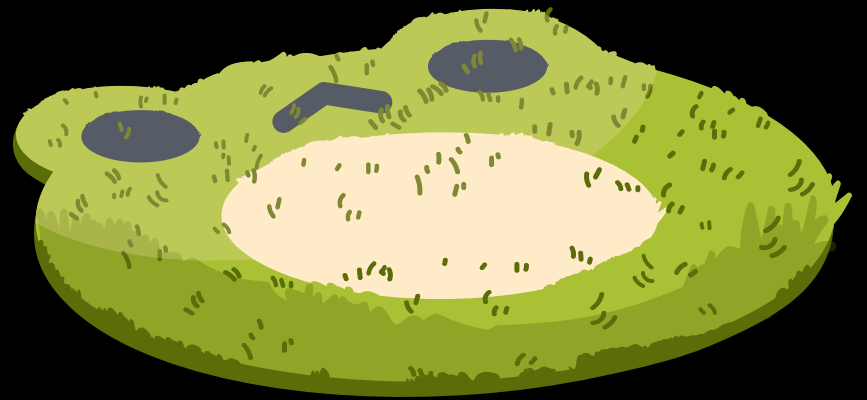
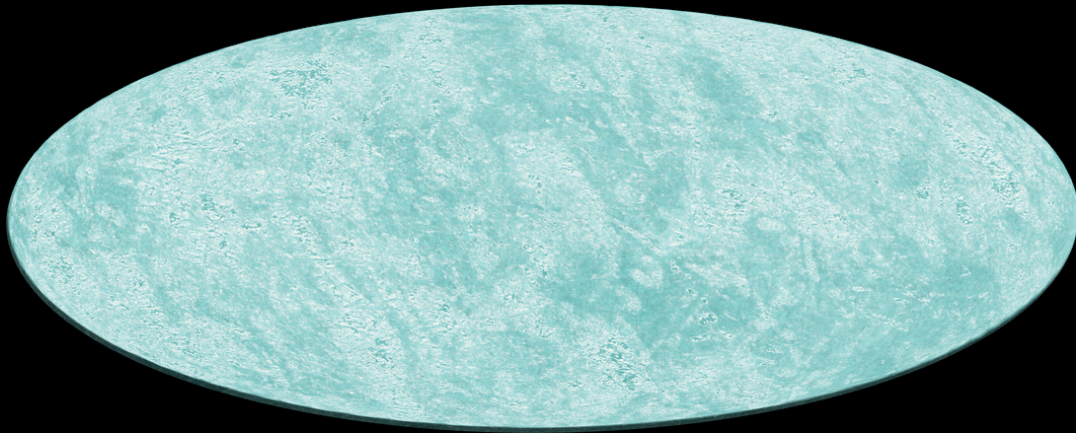
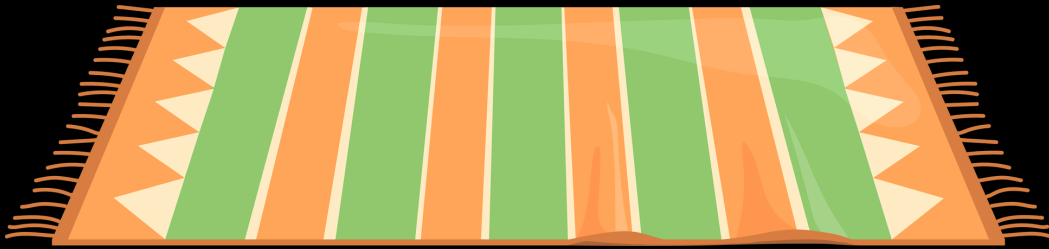
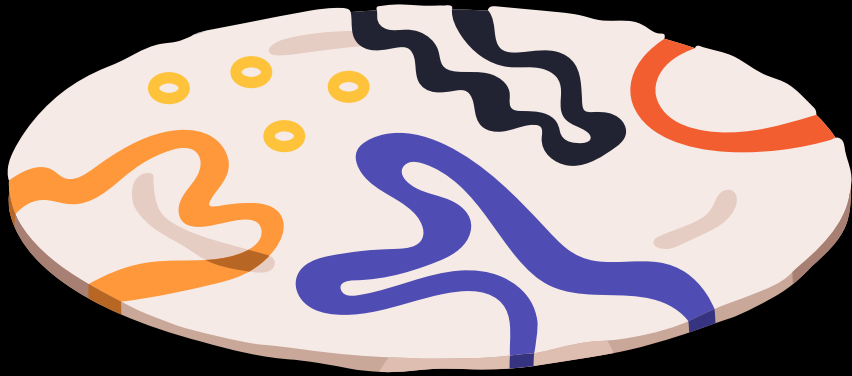



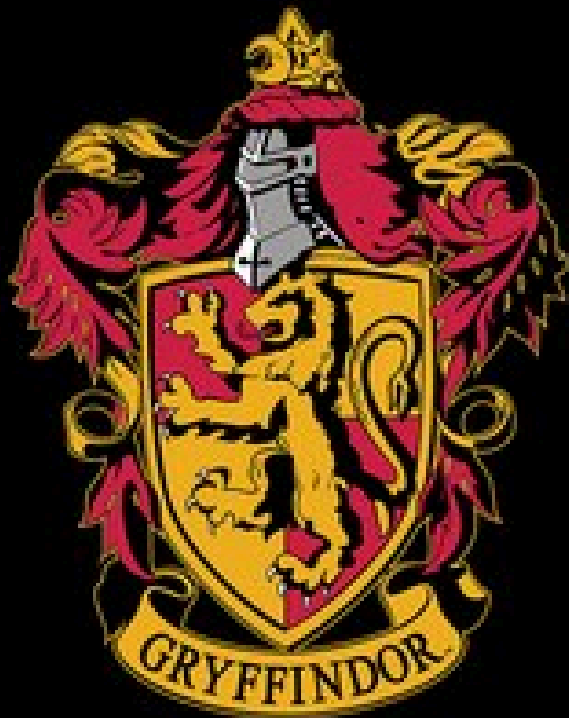

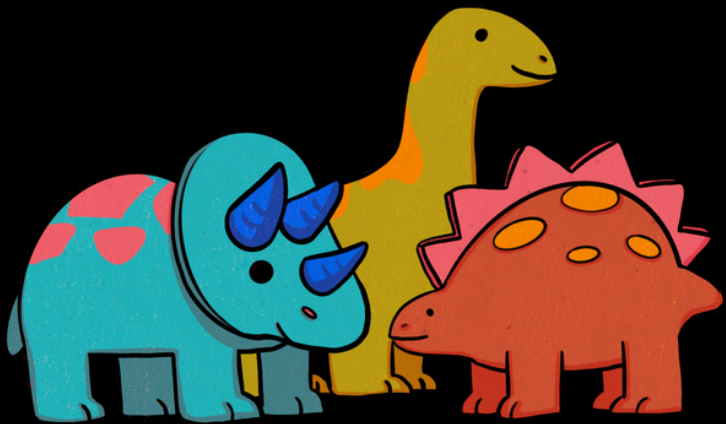

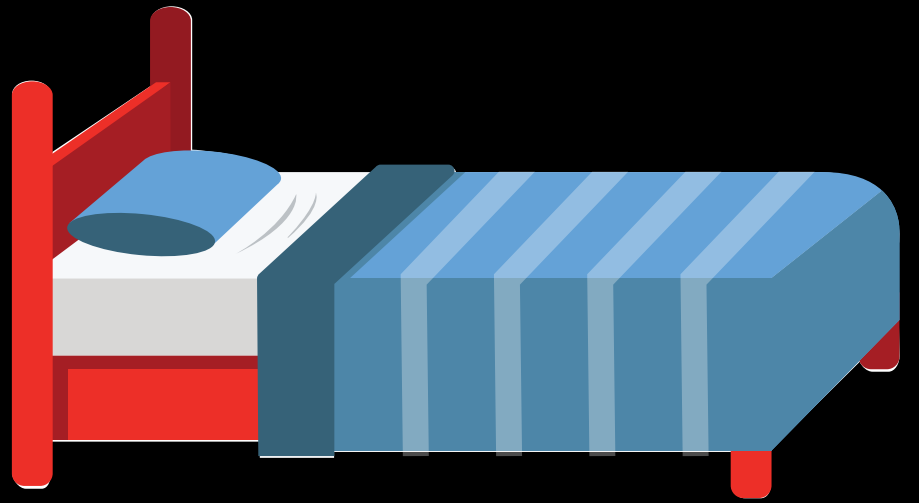

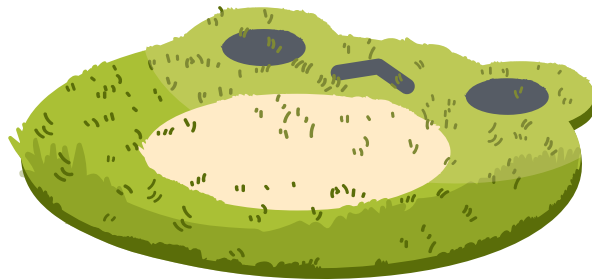







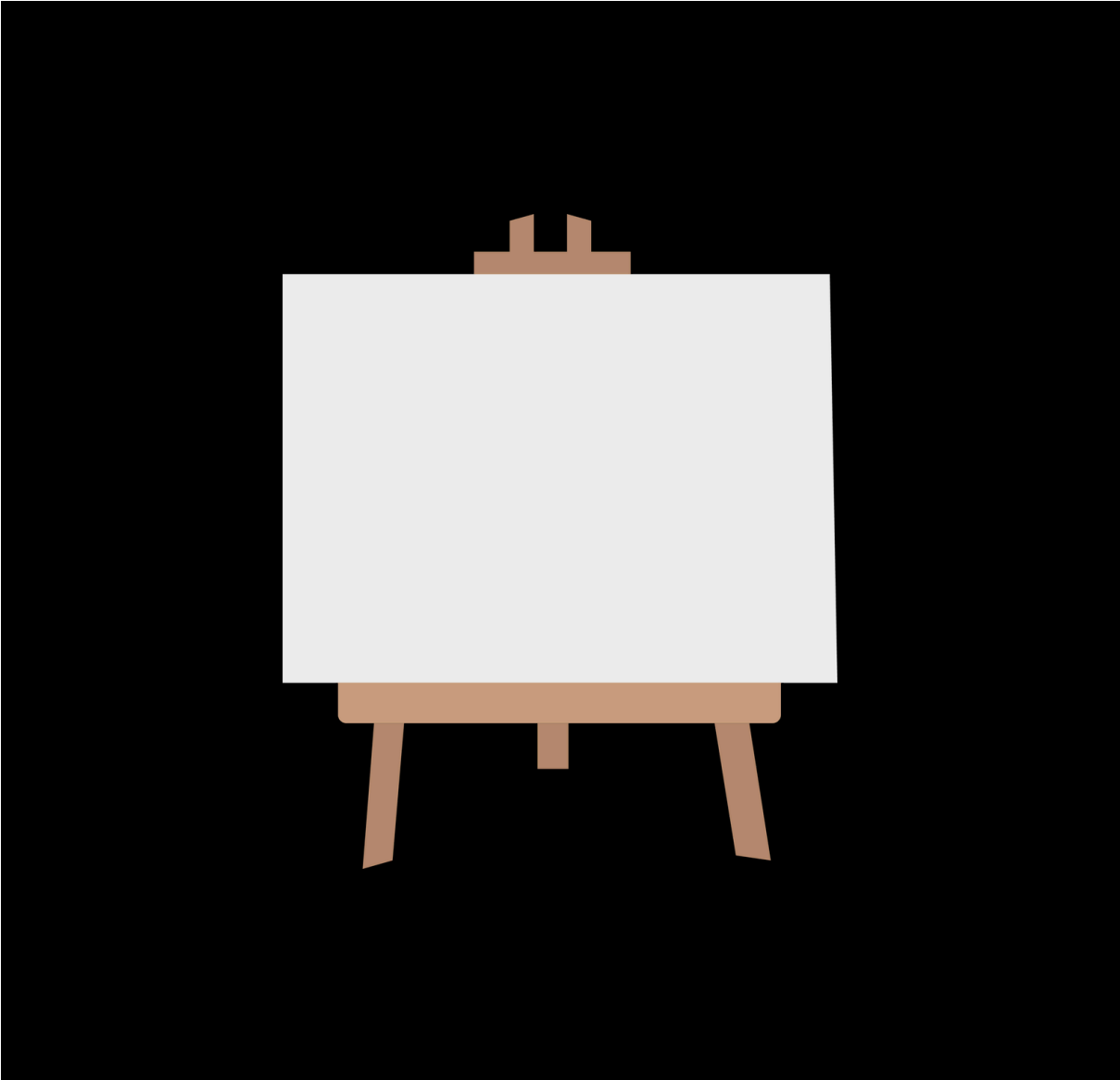

# SAMPLE STUDENT COLLAGE

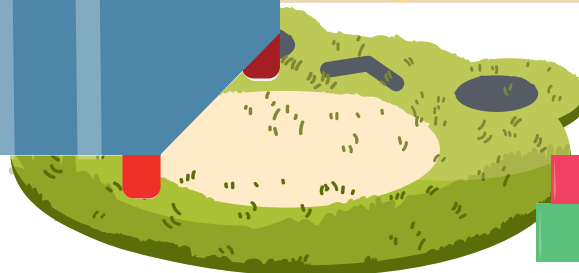
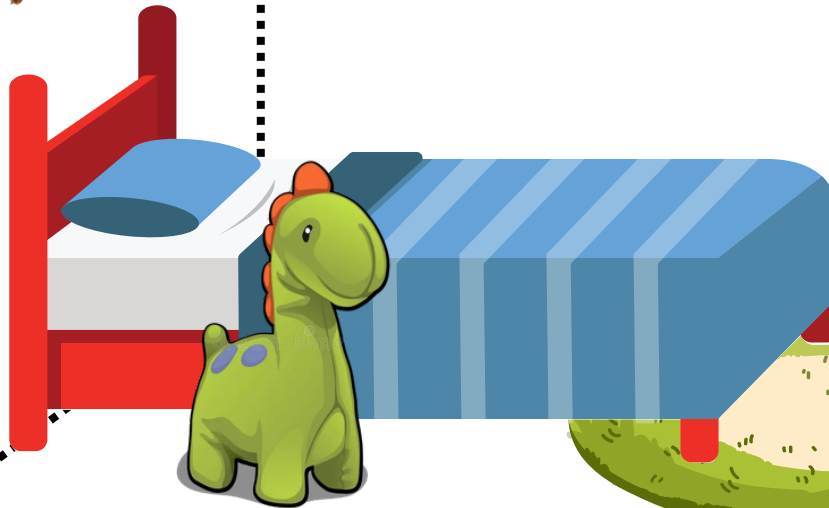

# PARENT LETTER

## Julia Sanders

Student Teacher - Art Class



### Teacher Introduction

Hello! My name is Julia Sanders and I am a student teacher in Miss Cushwa's art class until March 20<sup>th</sup>. I'm really excited to be your child's other art teacher and to help your students learn and appreciate art! You can ask your student if they have met me and if they can tell you any fun facts that I shared with them my first week. They may mention my best furry friend Winston, or that I showed them my first artwork from kindergarten - in the same frame that my mom put it in years ago.

### Family



I'm married and have three children

### What are they learning?

In this lesson, I want the students to learn that through art they can design a place and fill it with objects and furniture that has meaning to them. I also want them to learn how to use perspective to add dimension to their drawings.

### Previous Student Example



### Education

2024 - 2026

#### Kutztown University of Pennsylvania

- I'm a graduate student working on achieving my art education certification and will be certified in May.

March 26 -  
May 14

#### Pottsgrove Middle School

- I will be student teaching at the middle school after leaving Miss Cushwa's classroom.

### 5th Grade Dream Bedroom Lesson

I'm teaching your 5th graders a lesson about 1 point perspective through the planning and drawing of their Dream Bedroom. They are designing and decorating their rooms to be a reflection of their identity and interests. They are learning how to make a flat artwork look like it has depth and dimension. We started with pictures of their own school hallways to practice drawing lines in perspective. I can't wait to see how their bedrooms look as they color them with colored pencil and add details.

### Vincent Van Gogh's Bedroom Painting Shown in Class

